

The how-to magazine of electronics...

AN INTERTEC PUBLICATION

ELECTRONICTM

Service & Technology

APRIL 1988/\$2.50

TV servicing and the composite video waveform

An oscilloscope update • Thermistor bridges

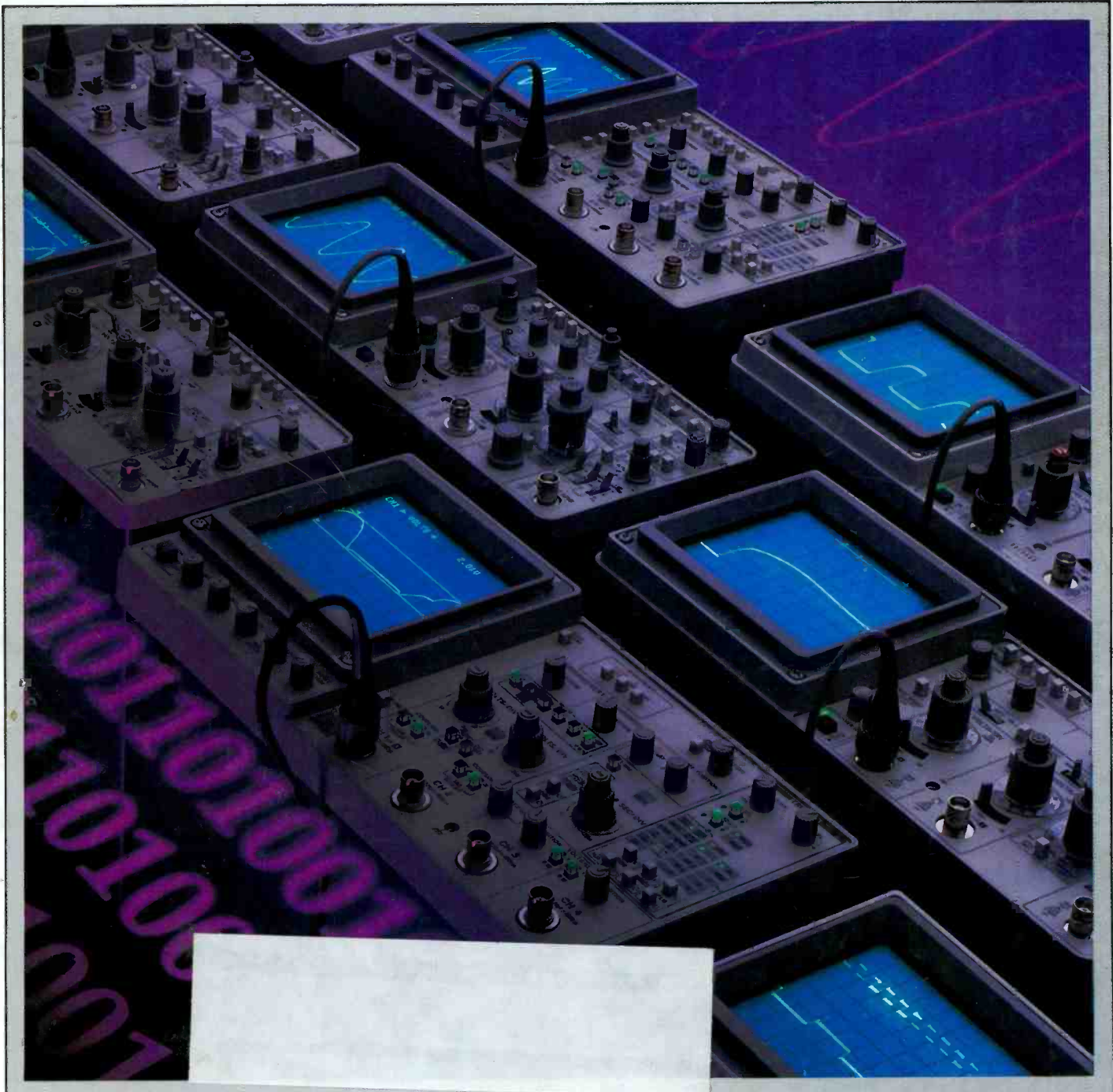

More Functions. Smaller Budget.

Beckman Industrial Circuitmate™ DMMs put hFE, Logic, Capacitance, Frequency and True RMS In Your Hand. For Less.

Get more, for less. It's a simple definition of value. For DMMs, value means finding the combination of capabilities that meets your needs at the right price. Without losing sight of accuracy and reliability. If you want more functions at a low price, Beckman Industrial's Circuitmate™ Digital Multimeters are the best value around.

From the pocket-sized DM20L to the DM850, with true RMS capability and accuracy to 0.05% ± 1 digit, Circuitmate DMMs give you the functions you need.

For instance, the DM20L puts both a Logic Probe, a transistor gain function (hFE), and a full range of DMM functions in the palm of your hand. For only \$79.95.

Then there's the DM25L. Where else does \$99.95 buy you a Logic Probe, capacitance measurement, transistor gain function (hFE), and 24 DMM ranges including resistance to 2000 megohms? Nowhere else.

When high accuracy counts, there's the DM800 with a 4 1/2 digit display. The DM800

DM20L Pocket-Size w/Logic \$79.95*

TTL Logic Probe: 20MHz
Hi/lo/off indications
Detects 25ns pulse widths

hFE (NPN or PNP):
1 range (1000)

DMM: Input Impedance—
10 Megohms
DCA/ACA-5 ranges
(200µA to 2A)

Ohms-8 ranges (200 ohms
to 2000 Megohms)

Continuity beeper



also gives you frequency counting. A full-function DMM, and more, doesn't have to cost over \$195.00. If it's a Circuitmate DM800.

Or, for a few dollars more, get true RMS (AC coupled) to let you accurately measure non-sinusoidal AC waveforms, and all the capability of the DM800, in the DM850.

Of course, there's a whole range of Circuitmate DMMs and service test instruments, including the DM78 autoranger that

DM850 True RMS

4 1/2 digits. DCV accuracy is .05% +3 digits

True RMS

Frequency counter to 200KHz

Data Hold display capability

Continuity beeper

Built-in bail

Anti-skid pads

Price: DM850 (True RMS) . . . \$219.95*
DM800 (Average) . . . \$195.00*



fits in a shirt pocket, yet gives you a full size 3 1/2 digit, 3/8" readout. Not to mention a complete line of accessories like test leads, current clamps, even probes that can extend your DMMs range and sensitivity. All designed to work flawlessly with your Beckman Industrial Circuitmate DMM.



See your Beckman Industrial distributor and discover more DMM performance. For less.

*Suggested list price (\$US) with battery, test leads and manual.

In Service Instruments, We're The One.

Beckman Industrial™

Beckman Industrial Corporation, Instrumentation Products Division
A Subsidiary of Emerson Electric Company
3883 Ruffin Road, San Diego, CA 92123-1898
(619) 495-3200 • FAX: (619) 268-0172 • TLX: 249031
© 1987 Beckman Industrial Corporation

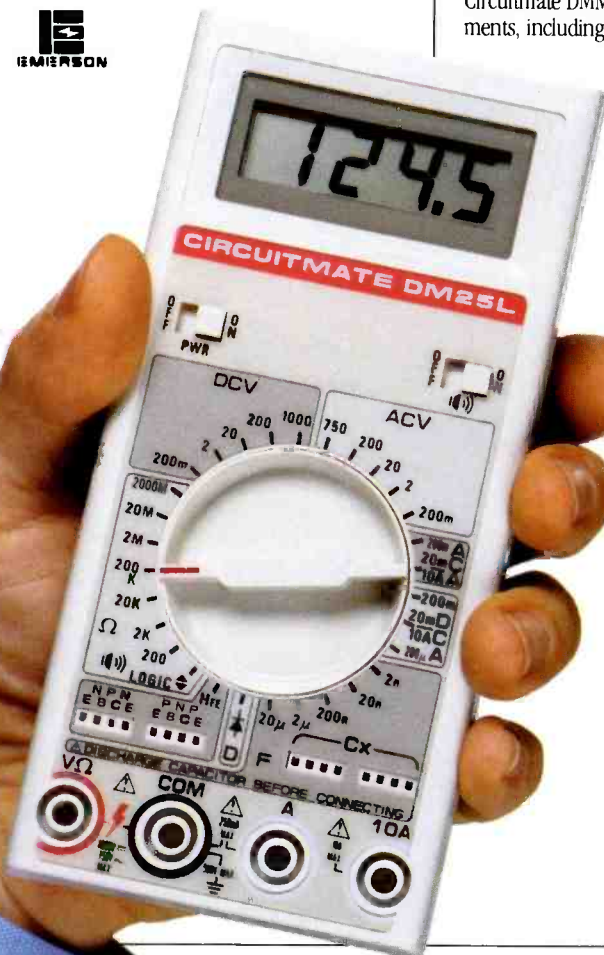

DM25L Capacitance, Logic, hFE \$99.95*

TTL Logic Probe: 20MHz
Hi/lo/off indications
Detects 25ns pulse widths

Capacitance: 5 ranges
(2nF to 20µF)

hFE (NPN or PNP):
1 range (1000)

Continuity beeper

Built-in bail

Anti-skid pads

Circle (1) on Reply Card



CHEMTRONICS NEW PREMOISTENED PADS AND GAS DUSTERS MAKE SERVICING EASIER

When Vann's Electronics — Great Neck, New York contacted us with lots of good news about our new products, we thought you would like to hear about it too. Vann's Electronics has been growing since 1966. Its staff of 11 technicians services everything from TVs and VCRs to home computers and telephones. They even maintain service contracts for electronic equipment at many New York hospitals.

Here's what Vann's has to say:
 "Your **Optic Prep**™ is ideal for projection TV. The professional one-step packet is more convenient than bringing liquid chemicals into someone's house."
 "**Screen Prep**™ antistatic cleaner is excellent for TV screens and is a profitable resale item for offices with CRTs."
 "IPA saturated **Chemswab**™ and **Chempad**™ are perfectly designed for magnetic head maintenance and general electronic cleaning."

"**Gold Guard**® and **TF Pads**™ clean and preserve contacts easily. The lint-free pad provides a gentle burnishing action not achievable with sprays and they occupy very little space in our tool kits."
 "Handy **Ultrajet**® compressed gas dusters are used all day long. It's our first step in repairing any electronic equipment."
 For free evaluation samples, contact us today. We're sure you will agree with leading industry professionals that Chemtronics makes servicing easier.

Chemtronics
 Keeping pace with advanced technology
 Chemtronics Inc.
 681 Old Willets Path
 Hauppauge, NY 11788
 516-582-3322
 Telex 968567

Circle (3) on Reply Card



Page 8

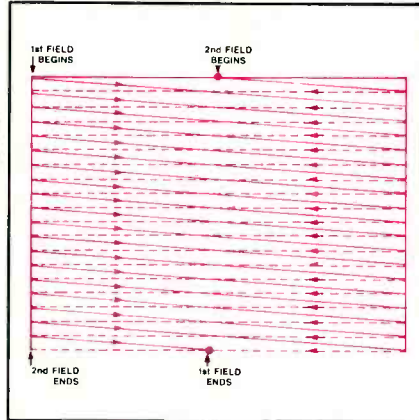

Page 10



Page 22

FEATURES

10 TV servicing and the composite video waveform

By Conrad Persson

Sure, you can service a television without understanding the NTSC composite video waveform. Knowing how the TV circuits are directed by the waveform to create the picture, however, can help you zero in on trouble spots.

22 An oscilloscope update

By Conrad Persson

Thinking about buying a new scope? Today's oscilloscopes offer plenty of new features to choose from, including on-screen readout, waveform storage, the convenience of miniaturization, and PC compatibility.

The how-to magazine of electronics

ELECTRONIC
Servicing & Technology

DEPARTMENTS

4 Editorial

The NTSC composite video waveform

6 News

8 Technology

The ultimate in easy listening

17 Literature

18 SYMCURE

20 Test Your Electronics Knowledge

31 Profax

46 Books/Photofact

48 Products

52 What Do You Know About Electronics?

Thermistor bridges

56 Audio Corner

CD digital error correction

58 Computer Corner

The ripple counter

60 Video Corner

High fidelity in VCRs—Part II

64 Readers' Exchange

68 Advertisers' Index

ON THE COVER

Using an oscilloscope used to be somewhat of a challenge: counting graticule divisions and horizontal scale divisions, finding the electron beam, even knowing where to trigger on the waveform. The newest technology in oscilloscopes, however, now gives servicers many features to choose from for their specific needs. (Photo courtesy of Tektronix.)

LEADER

LBO-516

NOW 100-MHz OSCILLOSCOPE

✓ \$1495 Manufacturer's Suggested List Price

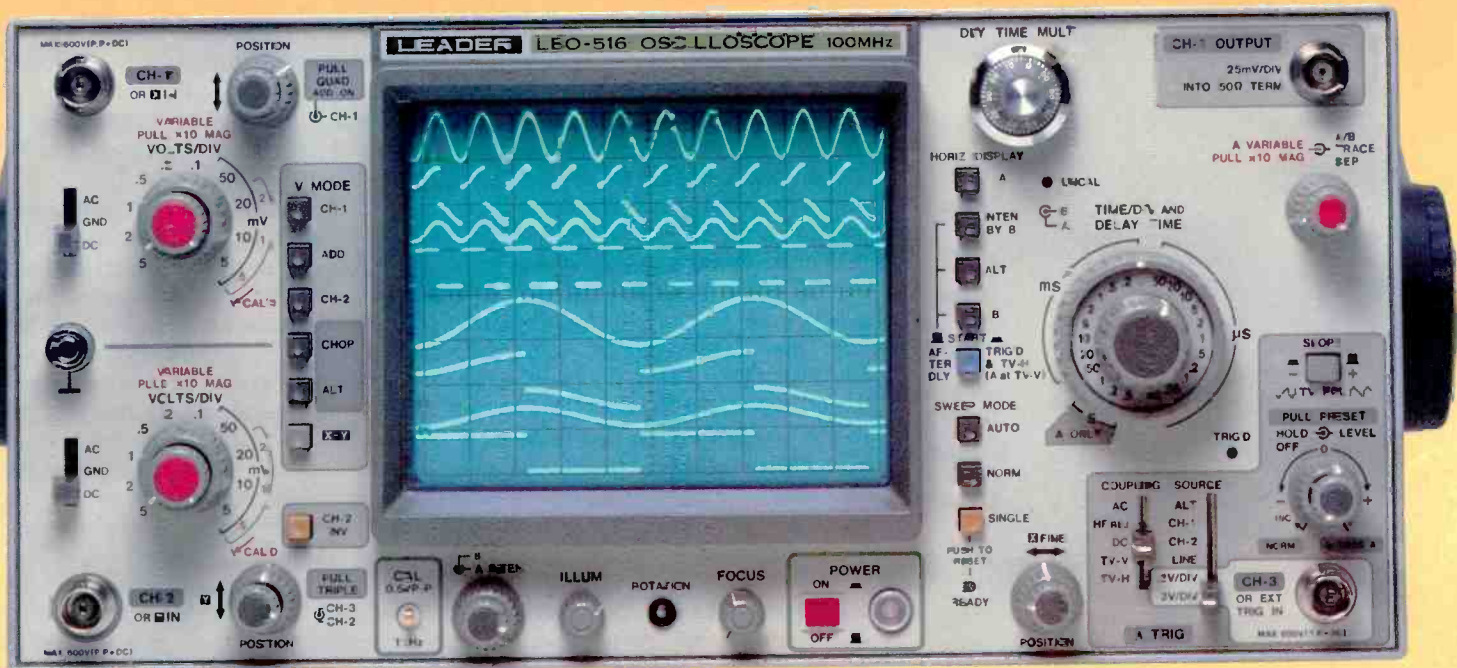

✓ 8-Trace Capability

✓ Alternate Triggering

✓ 2 Time Bases

✓ 3-Channel Input

✓ Clear, Bright Trace

✓ 0.5 mV Sensitivity

✓ 2-Year Warranty

✓ Coast-to-Coast Service

For immediate delivery or more information call toll-free

✓ **800-645-5104**

In New York State
516-231-6900

For professionals who know the difference.

LEADER
Instruments Corporation

380 Oser Ave., Hauppauge, NY 11788

For Information Circle (4) on Reply Card
For Demonstration Circle (46) on Reply Card
www.americanradiohistory.com

The NTSC composite video waveform

If you've been servicing televisions, you probably know exactly what makes them tick—the components, you might think. It's entirely possible, however, to fix a TV set without understanding another necessary ingredient—the NTSC composite waveform. But, once you get an idea what the waveform does, you get a new perspective on how the television works.

Without this waveform, broadcasters wouldn't be able to broadcast in both black-and-white *and* color. By the time monochrome television had been well proven as a mass-communications medium, much study had been done to come up with a scheme to broadcast in color. A number of ideas were proposed, but the one imperative was that viewers must be able to receive the broadcast in black and white on existing monochrome sets and in color on new color sets. Much was made about "compatible" color.

In order to come up with such a compatible color broadcast technique, a group was formed of broadcasters, television manufacturers and FCC members. This group, dubbed the National Television System Committee (NTSC), was given the task of developing a system that would broadcast television programs in color while allowing existing monochrome TV sets to receive the same signal.

Opinion is divided as to how successful the effort was, especially when you compare the picture quality of NTSC color television to the superior quality of the other two standards in effect in different parts of the world: phase alternation line (PAL) and sequential

couleur a memoire (SECAM). The NTSC waveform has worked reasonably well, however, and has brought good quality color television to homes throughout the United States for a number of years.

The waveform that this committee developed to carry the color TV signal while leaving the monochrome signal unchanged is called the *NTSC composite video waveform*. This waveform, once it has been received and processed, performs a number of tasks: It synchronizes the horizontal and vertical oscillators to keep them in step with the transmitting station; it carries the brightness (luminance) information to paint a monochrome picture on the screen; and it contains the color information necessary to paint a picture of the correct colors on the screen of a color television.

TV servicing can be performed without a thorough understanding of this waveform, but if you understand the NTSC composite video waveform and how it affects the various circuits in the television, it should considerably enhance your ability to diagnose problems when they occur. To that end, we present in this issue a detailed treatise on the luminance portion of the NTSC as a review for the experts and as a first exposure to the new techs. We hope you find it useful.

In a future issue, we will describe the color generating-components and color-processing circuits of the television to round out our coverage of the NTSC signal.

Nile Conrad Pearson



PHILIPS

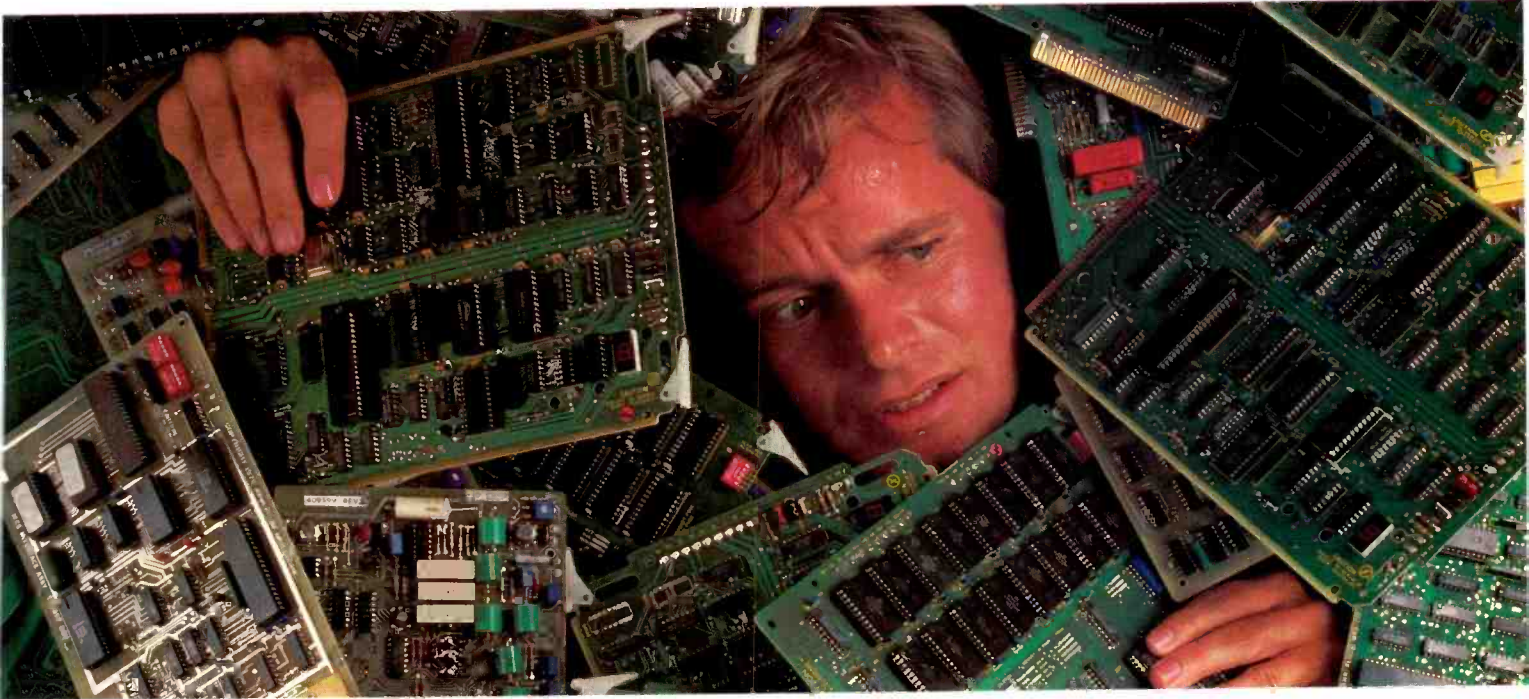

How to rescue yourself from a landslide of microprocessor board failures.

Complementing traditional troubleshooting tools, the Fluke 9010A can help decrease your board repair times by 55-80%.

You've got your oscilloscopes, your logic analyzers and your signature analyzers. But Fluke offers a better way to troubleshoot: the tool you'll reach for most. It's the 9010A Troubleshooter, a versatile board tester that's so easy to use, you can start testing the very first day.

The Fluke 9010A has a proven track record in saving repair time and substantially reducing board float. In fact, it has become the microprocessor repair tool of choice for over 2800 companies worldwide, including the leading computer and electronics manufacturers.

Test the easy way: from the micro-processor socket.

To begin board repair, remove the micro-processor from its socket and insert the interface pod connector in its place. Each

element of the microprocessor kernel (the bus, ROM, RAM and I/O) can be tested with a few simple commands.

Fluke's patented emulation technology offers real time testing and complete visibility throughout the circuit. This lets you test even the tough problem areas, including DMA, disk, video, communications and peripheral controllers. All diagnostic messages are presented in simple-to-understand English.

Comprehensive support from Fluke.

The 9010A supports over 50 micro-processors (including 180X, 6502, 680X, 680XX, 803X, 804X, 805X, 808X, 874X, 80X86, 9900, Z80, Z800X, 8751). And it is backed by Fluke's complete support network, which offers training courses nationwide on test strategy, basic operation and even μ P fundamentals.

In addition to the 9010A, the leader in emulative board test technology also offers the 9100A Digital Test System for a fully automated repair solution; plus the 90 Series, a compact inexpensive troubleshooting solution for 6809, Z80 and 8085 μ Ps.

To learn how you can escape the landslide, get your free video brochure "The 9010A μ P Board Repair Solution."

Call 1-800-44-FLUKE, EXT. 88 today.

John Fluke Mfg. Co., Inc. P.O. Box C9090,
M/S 250C, Everett, WA 98206
U.S.: 206-356-5400 CANADA: 416-890-7600
OTHER COUNTRIES: 206-356-5500

© Copyright 1988 John Fluke Mfg. Co., Inc.
All rights reserved. Ad No 0181-F9010.



The 9010A Microsystems Troubleshooter



Circle (5) on Reply Card

Surge protectors get insurance cut

Kemper National P&C Companies is the first insurer to revise business electronic equipment policies to include a 15% premium discount for customers who install surge protectors on their electronic equipment. According to the company, although the protectors cannot help in a direct lightning strike, the

devices do eliminate most surge-related losses to electronic equipment. The credit will be available in all states except Texas.

EIA offers free workshops

The Electronic Industries Association is offering the following 2- and 5-day free workshops on VCRs, CDs, micro-

processor/CDs (MP/CD), theory and hands-on training. The workshops are organized by the Consumer Electronics Group of the EIA and co-sponsored by national service organizations such as NESDA/ISCET and state departments of vocational education. (Contact the EIA at 2001 Eye St. N.W., Washington, DC 20006; 202-457-4900.)

Workshops for consumer electronics technicians* (CD and VCR)

Site	Course	Dates
Cleveland, TN	VCR	May 23-27
Waltham, MA	VCR	June 6-10
Brooklyn Park, MN	CD	June 7-8
Detroit	CD	June 9-10
Cleveland, OH	VCR	June 20-24
Columbus, OH	VCR	June 27-July 1
Louisville, KY	VCR	July 5-9
Lakeland, FL	VCR	July 11-15
Goodland, KS	VCR	July 11-15
Nashville, TN	CD	July 15-16
Ft. Lauderdale, FL	VCR	July 18-22
San Francisco	VCR	July 18-22
St. Charles, IL	CD	Aug. 2-3, 5-6
Tacoma, WA	CD	Aug. 15-16
Syracuse, NY	VCR	Aug. 22-26
Jacksonville, FL	CD	to be set

*For specific sites and local contacts, check with NESDA/ISCET national headquarters in Fort Worth, TX (telephone number: 817-921-9061 or 817-921-9101).

Workshops for instructors in vocational education* (MP/CD)

Site	Course	Dates
Jackson, MS	MP/CD	June 13-17
Baltimore	MP/CD	June 20-24
Indianapolis	MP/CD	June 20-24
Jefferson City, MO	MP/CD	June 27-July 1
Sante Fe, NM	MP/CD	June 27-July 1
Des Moines, IA	MP/CD	July 5-9
Denver	MP/CD	July 11-15
Frankfort, KY	MP/CD	July 18-22
Helena, MT	MP/CD	July 18-22
Atlanta	MP/CD	July 25-29
Olympia, WA	MP/CD	Aug. 1-5
Stillwater, OK	MP/CD	Aug. 8-12
Honolulu	MP/CD	Aug. 10-14
Honolulu	MP/CD	Aug. 15-19
Springfield, IL	MP/CD	Aug. 29-Sept. 2

*For specific sites, instructors should contact state directors of vocational education.

The how-to magazine of electronics

ELECTRONIC

Servicing & Technology

ELECTRONIC SERVICING & TECHNOLOGY is the "how-to" magazine for technicians who service consumer electronics equipment. This includes service technicians, field service personnel and avid servicing enthusiasts who repair and maintain audio, video, computer and other consumer electronics equipment.

EDITORIAL

Nils Conrad Persson, *Editor*
 Carl Babcoke, *Consumer Servicing Consultant*
 Tom Cook, *Senior Managing Editor*
 Alisa Carter, *Associate Editor*
 Joy Culver, *Editorial Assistant*
 Darryll Fortune, *Editorial Assistant*
 Kathy Mickelson, *Editorial Assistant*

CONSULTING EDITORS

Homer L. Davidson, *TV Servicing Consultant*
 Christopher H. Fenton, *Circuit Fabrication Consultant*
 Victor Meeldijk, *Components Consultant*
 Kirk G. Vistain, *Audio Consultant*
 Sam Wilson, *Electronics Theory Consultant*

ART

Kevin Callahan, *Art Director*
 Barbara Miles, *Graphic Designer*

BUSINESS

Cameron Bishop, *Group Vice President*
 Eric Jacobson, *Publisher*
 Greg Garrison, *Sales Manager*
 Stephanie Hanaway, *Promotions Manager*
 Kelly Hawthorne, *Promotions Coordinator*
 Dee Unger, *Advertising Supervisor*
 Catherine Grawe, *Advertising Coordinator*

ADVERTISING

Regional advertising sales offices are listed in classified pages.

ADMINISTRATION

R. J. Hancock, *President*
 Doug Riemer, *Circulation Vice President*
 Jane J. Powell, *Circulation Director*
 Jo Ann DeSmet, *Fulfillment Manager*
 Barbara Clare, *Reader Correspondent*



Member, Audit Bureau of Circulation



Member, American Business Press



Member, Electronic Servicing Dealers Association

CORRESPONDENCE

Editorial, advertising and circulation correspondence should be addressed to: P.O. Box 12901, Overland Park, KS 66212-9981 (a suburb of Kansas City, MO); (913) 888-4664. Home office fax: 913-888-7243; Home office telex: 42-4156 INTERTEC OLPK

SUBSCRIPTION PRICES: one year \$18, two years \$30 in the USA and its possessions. Foreign countries: one year \$22, two years \$34. Single copy price \$2.25; back copies \$3.00. Adjustment necessitated by subscription termination to single copy rate. Allow 6 to 8 weeks for new subscriptions.

PHOTOCOPY RIGHTS: Permission to photocopy for internal or personal use is granted by Intertec Publishing Corp. for libraries and others registered with Copyright Clearance Center (CCC), provided the base fee of \$2 per copy of article is paid directly to CCC, 21 Congress St., Salem, MA 01970. Special requests should be addressed to Eric Jacobson, publisher. ISSN 0278-9922 \$2.00 + 0.00



© 1988 All rights reserved.



SWEEP AND FUNCTION GENERATOR COMBINED IN ONE CONVENIENT INSTRUMENT

The high quality, cost-effective Model 3017 generates sine, triangle and square waveforms at frequencies from 0.2Hz to 2.0MHz in seven ranges. Continuously adjustable sweep width, 1000:1 ratio has settable Hi/Lo range. Sweep time is adjustable from 0.5 to 30 seconds. TTL and CMOS pulse outputs and variable amplitude output for added versatility. \$319.00. Contact: B&K-PRECISION, 6470 W. Cortland St., Chicago, IL 60635. (312) 889-1448.

Circle (50) on Reply Card



4 1/2 DIGIT RMS BENCH DMM WITH 0.05% VDC BASIC ACCURACY

The Model 2833 measures volts to 1000 VDC and VAC current to 20A DC and AC, resistance to 20 MΩ, dBm from -48dB to 62.21dB. Measures frequency to 200kHz. Audible continuity check, diode test. \$330.00. Contact: B&K-PRECISION, 6470 W. Cortland St., Chicago, IL 60635. (312) 889-1448.

Circle (51) on Reply Card



HIGH PERFORMANCE 3 1/2 DIGIT BENCH DMM/CAPACITANCE METER

Measures voltage, resistance, current and capacitance to 20 μF. Audible continuity check and diode test. Model 2832. \$175.00. Contact: B&K-PRECISION, 6470 W. Cortland St., Chicago, IL 60635. (312) 889-1448.

Circle (52) on Reply Card



150 MHz RF SIGNAL GENERATOR

This signal generator, Model 2005, covers 100kHz to 150MHz in six fundamental bands and 450MHz in harmonics. It has a frequency monitor output that allows connection to an external frequency counter. Amplitude modulation is continuously variable, 0-100% of modulation from 50Hz to 20kHz, plus many other features. \$195.00. Contact: B&K-PRECISION, 6470 W. Cortland St., Chicago, IL 60635. (312) 889-1448.

Circle (53) on Reply Card



LOW-COST CALIBRATOR KEEPS SCOPES ACCURATE

No need to send oscilloscopes out for calibration. With the B&K-PRECISION Model 1400 you can quickly and easily calibrate your scope. It provides time and amplitude signals with 0.015% time accuracy and 0.5% amplitude accuracy and can even be used as a signal source in test applications. \$499.00. Contact: B&K-PRECISION, 6470 W. Cortland St., Chicago, IL 60635. (312) 889-1448.

Circle (54) on Reply Card



CONVERT ANALOG OSCILLOSCOPE TO DIGITAL STORAGE AT A FRACTION OF THE COST

Three simple cable connections can convert your analog scope to a digital storage oscilloscope. With the Model 2501 you can capture single shot events, store and magnify waveforms for analysis and review pre-trigger information at 0%, 50%, or 100%. There is even a plotter output so you can hard copy the wave-form. This compact unit weighs less than 4 pounds and is small enough to conveniently set on top of your scope. \$795.00. Contact: B&K-PRECISION, 6470 W. Cortland St., Chicago, IL 60635. (312) 889-1448.

Circle (55) on Reply Card

Highest Bandwidths with Lowest Prices... B&K-PRECISION



Model 2120
20 MHz
dual-input

\$479⁰⁰

Model 2125
20 MHz
dual-time base

\$570⁰⁰



Model 441A
40 MHz
dual-input

\$845⁰⁰

MEASURE TO THE
MAX
WITH MAXTEC

If you're looking for the most scope performance per dollar look to B&K-PRECISION! Compare our specs, features and prices...

2120 20MHz Dual-Trace • 1 mV/div sensitivity • AUTO/NORM triggered sweep with AC, TVH, TVV and Line coupling • Calibrated 18 step time base with x10 mc/gnifer • X-Y operation • Includes probes

2125 20MHz Dual-Trace • 1 mV/div sensitivity • 18 delayed sweep ranges and variable X1 to X10.3 display modes • Component tester for capacitors, inductors, semiconductors • Includes probes

441A 40MHz Dual-Trace • 1 mV/div sensitivity • 20 calibrated sweeps • Internal, illuminated graticule • Video sync separators • X-Y operation • X10 sweep magnification • V mode • Sum & difference capability • Channel B output • Includes probes

For immediate delivery or complete information contact your local distributor or:



3470 W. Cortland St. • Chicago, IL 60635 • 312-889-1448

International Sales, 6470 W. Cortland St. Chicago, IL 60635

Canadian Sales, Atlas Electronics, Ontario

South and Central American Sales, Empire Exports Plainview, NY 11803

Circle (6) on Reply Card

The ultimate in easy listening

Programming an evening's entertainment is easy with a computer interface that automates your music system.



The computer interface automates an entire music system, including radio, cassette and CD.

A computer interface designed to fully automate a music system has been introduced by the Revox division of Studer Revox America, Nashville, TN.

The Revox B203 Timer Controller can be connected to a personal computer for virtually complete automation of the Series 200 music system, which includes a receiver, a tuner/pre-amplifier, a CD player and a cassette deck.

How it works

An optional software package is available for the interface, which is compatible with any MS DOS (fully IBM-compatible) home or personal computer. The PC-linked interface con-

nnects to the music components through an RS-232 port. The software package prompts the user and creates a series of commands from the prompts. Almost all functions and transport operations can be programmed. The computer automatically checks the audio equipment to determine whether commands are being executed and completed.

Musical entertainment for an entire evening can be programmed, with random access of CD tracks and cassette segments. For example, the system can be programmed to switch from radio programming, to CD tracks, to cassette segments and then back to radio at specified times to correspond to activities that are expected to occur.

Other time-programming options include programming by single date and time or programming by day of the week and time. Single date and time allows programming of a 1-time event, such as an unattended recording. Day of the week and time programming allows repeatable musical events, such as listening to or recording a favorite weekly program.

Another optional feature is the B205 remote-control module. The remote control allows the listener to change music sources with one button. Similar 1-touch operation also can be made directly from any of the components in the audio system.

ES&T INC.



PHILIPS

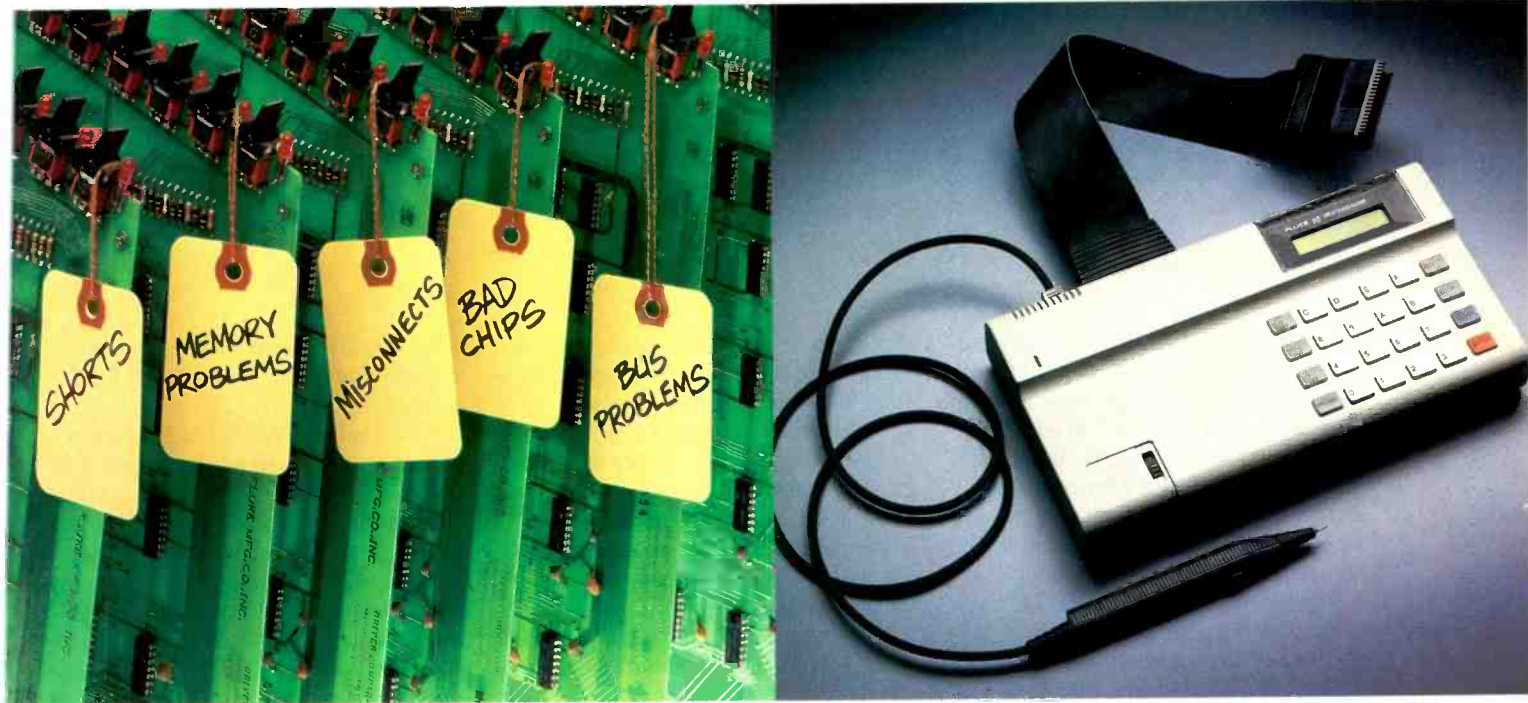

Multiple Problems.

For microprocessor board troubleshooting and service, nothing expands your diagnostic capabilities — and simplifies your operation — like the new Fluke 90 Series.

This unique μ P board tester gives you a complete range of test functions:

- Bus Tests
- Memory Tests
- I/O Tests
- QuickTrace™ Probe Test, to automatically identify and display unknown nodes.

QUICKTRACE
A02

- In all, 16 different preprogrammed tests make the 90 Series a powerful stand-alone troubleshooting instrument.

Add the power of a PC.

Connect the 90 Series' RS-232 port to a PC or terminal and access advanced troubleshooting functions, such as Break-Point and Frame-Point capabilities, memory upload and download, plus external trigger functions. You can save both test sequences and results, building documentation on different boards as you go.

Designed for real-time testing.

The 90 Series consists of three units, each designed for one of the three most commonly used 8-bit processors (Z80, 6809 or 8085).

Each tester clips directly onto the micro-processor, including soldered-in processors. Power is supplied by the Unit Under Test. The UUT continues to operate while diagnostics are executed, so you can even locate intermittent problems.

Easy on the technician, easy on the budget.

The 90 Series is small enough (11" x 6" x 3") to find a home on every service bench. Test results are fast and presented in English. Each diagnostic function is selected from a simple-to-follow menu, which greatly reduces training time.

The Fluke 90 Series is ideal for service and repair operations, as well as engineering prototype testing and technician training. And it's ideally priced at \$1395 (suggested U.S. list), available from leading electronic distributors.

To find out more about the Fluke 90 Series, or the products that made Fluke the leader in emulative board testing, the 9000

One Solution.

Micro-System Troubleshooter or 9100 Digital Test System, call today at **1-800-44-FLUKE ext. 33.**

The Fluke 90 Series. A single instrument for a multitude of problems.



The 90 Series μ P Board Tester

John Fluke Mfg. Co., Inc., P.O. Box C9090, M/S 250C, Everett, WA 98206.
U.S.: 206-356-5400 CANADA: 416-890-7600
OTHER COUNTRIES: 206-356-5500.

© Copyright 1987 John Fluke Mfg. Co., Inc. All rights reserved. Ad No. 1173-F90.



Circle (7) on Reply Card

TV servicing and the composite video waveform

By Conrad Persson

One of the things that's absolutely crucial to understanding TV circuits—both how they operate properly and what causes them to malfunction—is an understanding of how the signal reaches your home, whether it's broadcast by the local TV station and captured by the antenna or sent via cable and fed to the antenna inputs of the television.

For starters, contrast the NTSC composite video signal with a radio broadcast signal. With a broadcast audio signal, all you have to do, essentially, is process the modulated signal, pass it

Persson is editor of ES&T.

through a detector to separate the audio signal from the modulating signal, amplify the audio signal, apply it to a speaker and there you are—sound.

The TV signal that reaches the receiver is far more complicated because it has to do a lot more. It has to carry:

- the picture information, consisting of the brightness (luminance) and the color information;
- the sound information;
- the portion of the signal that synchronizes the TV horizontal circuits with the horizontal-position information in the signal; and
- the portion of the signal that synchro-

nizes the TV vertical circuits with the vertical-position information in the signal.

Now consider the set and its circuitry. One way to understand what's going on in a TV set is to consider what's going into it, what's coming out of it and what's happening inside.

The output of the television is quite simple (or appears to be): a moving picture and sound. The devices that produce the picture and the sound are *transducers*: They convert electrical signals into physical phenomena. The picture tube converts the appropriate electrical signals into light; the speakers convert the appropriate signals into sound. The operation of the speaker is relatively straightforward. Because of space limitations, we won't treat it here.

The picture tube, on the other hand, is a complex device. To produce a recognizable image on the screen, the picture tube requires the presence of several signals at once, all occurring exactly at the correct time.

Let's stick to monochrome pictures for this discussion. Of course, color is important, but we can get to a pretty good understanding of the relationship of the TV circuitry to the NTSC signal without talking about color.

The electron beam

The electron beam is what draws the picture. One good way to understand what's going on is to try to picture the electron beam as a stream of liquid coming out of a nozzle of a hose. This stream comes out at the back of the picture tube and is aimed at the inside of the screen. The electron gun is the pump. When the liquid hits the phosphor on the inside of the picture tube, light is emitted. The higher the pressure of the pump, the brighter the picture tube where it is struck by the beam.

Picture yourself in charge of the noz-

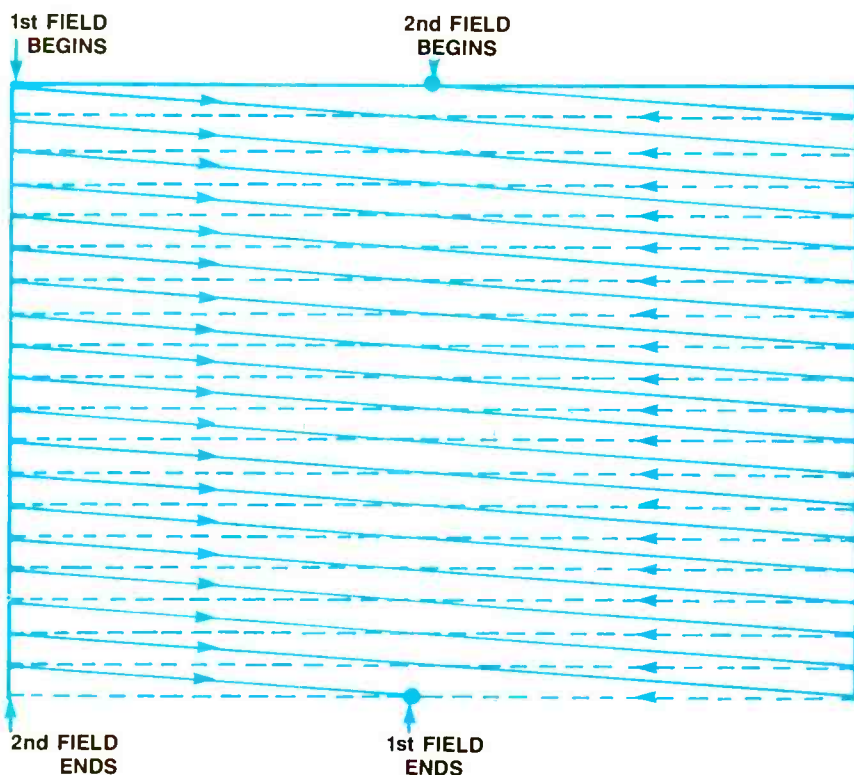

Figure 1. The TV picture is created by the movement of the electron beam across the screen, creating light of varying intensity to paint a picture. Each frame of the picture is created with two interlaced fields. If interlacing were not used, by the time the electron beam reached the bottom of the screen, the upper part of the screen would be fading. This would result in unacceptable and annoying flicker.

The NTSC waveform

For starters, let's put things into perspective. Although we're showing field 1 and field 2 of the NTSC composite video waveform as separate entities, what we really have is a continuous waveform that goes on and on and on—field 1 ends and field 2 begins, then field 2 ends and field 1 begins. The horizontal axis is time, and the vertical axis is signal voltage.

Also, note those portions of the signal marked *picture information*: We are only showing a small fraction of one field of the picture. What's going on here is that each time one of those tall pulses rises above the *blanking level*, it is being separated by the sync separator and is applied to the horizontal oscillator to keep the oscillator in sync. That wavy line

down there in the troughs between sync peaks, marked *video*, is a stylized representation of the video information being applied to the electron gun.

At the left of the trough is the time at which the electron beam is being aimed at the viewer's left side of the screen. The width of the trough represents the amount of time it takes for the horizontal circuits to move the electron beam from the extreme left edge of the screen to the extreme right edge. At the same time, of course, the vertical circuits are causing the electron beam to move slightly downward, so the line painted by the beam is diagonal across the screen. Actually, if you look very closely at a TV screen, you can see these lines.

While the electron beam is making its transit from left to right, the video signal being applied to the electron gun is varying in voltage, in step with the picture information being applied at the broadcast station. The higher the voltage applied by the signal, the darker the picture will be at that point on the screen. Note the relative brightness values pointed out on the drawing.

The drawing shows three lines of video before the vertical blanking interval and three lines after. If we could represent the entire waveform, you would actually see 262 of these lines, then a blanking interval, then another 262 lines and another blanking interval and so on, 60 times a second.

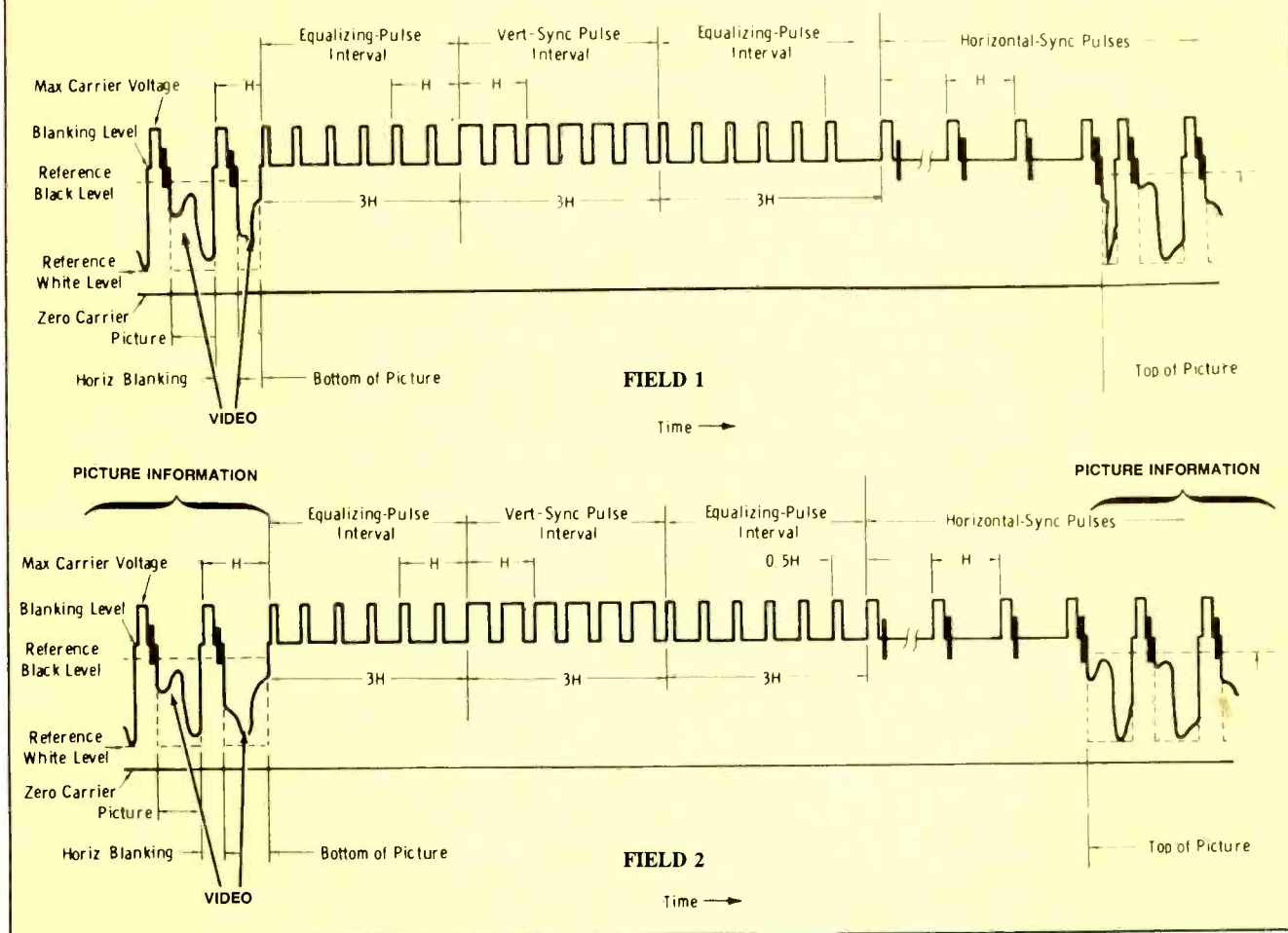

zle. In order to fill the screen with light, you have to direct the spray in an orderly fashion so that it strikes every point on the picture tube's surface over and over again.

Here's how it works: Starting at the top right of the picture tube (from your

point of view behind the screen), direct the spray at the screen and sweep the spray slightly downward and to the left. When the spray reaches the extreme edge of the screen, cut the spray off and quickly aim the nozzle back at the right edge of the screen. Leaving a space the

thickness of the line you just drew, turn the nozzle back on and sweep diagonally across the screen from edge to edge. You continue to do this, leaving a space each time, until the stream reaches the bottom center of the screen. Then you go back and, starting at the top center of

VCR IDLER TIRES



Now you can do VCR repairs faster and easier than ever before. **Parts Express** is now offering the most comprehensive idler tire kit available. With this kit in your stock room you can do over 90% of idler assembly repair jobs without waiting for parts deliveries.



FREE
cross-reference
included

The kit includes a **FREE** cross-reference listing over 80 manufacturer assembly numbers and over 200 model numbers. 150 tires total, 10 each of 15 different sizes in a high quality storage case with separate compartments for each size. Worth over \$400 retail value.

\$55.00

#400-900

VCR IDLER ASSEMBLIES



Part #	Replacement for	(1-9)	(10-up)
430-010	Sharp NIDL0006	4.15	3.70
430-020	Sharp NIDL0005	4.35	3.90
430-030	Sharp NPLY-V0051	4.15	3.70
430-050	Pana VXPO329	1.40	.95
430-052	Pana VXPO344	1.40	.95
430-055	Pana VXPO401	1.95	1.55
430-060	Pana VXPO521	4.50	3.90
430-100	Fisher 4204-00300	7.80	6.90
430-105	Fisher 4804-00100	1.50	1.25
430-110	Fisher 4904-00900	7.50	6.75
430-120	RCA 164113	3.75	2.95
430-125	RCA 150614	3.95	3.25
430-130	HIT 6413111	5.20	4.65

**FREE
CATALOG**

**Parts
Express**
International Inc.

CALL TOLL FREE

1-800-338-0531

340 E. First St., Dayton OH 45402
Local—1-513-222-0173

Circle (8) on Reply Card

the screen, fill in the lines you left blank. When you get to the bottom of the screen this time, the beam will be at the bottom right of the screen. Turn the nozzle off, move the beam to the top right of the screen and do it over again. (See Figure 1 for an illustration of what's going on.) Keep in mind that your *right* is the viewer's *left*. To someone on the other side of the screen, the beam is moving left to right.

If you're the gremlin operating an American TV set, you will have drawn a total of 525 lines (two alternate sets of 262 lines, or two *fields*) to make one complete still picture, also known as a *frame*, much like one frame of a motion picture. In the U.S. system, 59.94 of these fields (almost 30 frames) occur each second, producing the smooth motion pictures you see on the TV screen.

A little simple math will give you the frequencies involved. The rate at which these frames are painted on the screen—the *frame rate*—is 29.97 frames per second. The rate at which each field is painted on the screen—the *field rate*—is twice that, or 59.94 fields per second. But each field consists of 262 lines, so the *line rate* must be 262 times the field rate: 15,734.25/sec or 15,734.25Hz.

Now add the video

Here's what we have so far. The electron beam is being swept across the face of the screen at a rate of 15,734.25 times each second, making up a total of two fields, one frame, about 30 times a second. So far, so good, but that just gives us the *raster*, that bright light on the screen. In order to paint a picture, you have to cause certain areas on the screen to be almost white, other areas to be almost totally black and other areas to be some value of gray. You do this by regulating the pressure of the spray from your nozzle or, in the actual case, the voltage at the electron gun. This brightness information is called the *video*. In the case of a color set, this would consist of both brightness and color. Because we're dealing with monochrome, we're only concerned with brightness or *luminance*.

Synchronizing it all

There really isn't a little guy inside the TV sweeping the electron beam across the screen. An arrangement of electromagnets on the outside of the picture-tube neck is actually doing the sweeping. One of the characteristics of

an electron beam is that it will be deflected by a magnetic field.

The horizontal oscillator and vertical oscillator provide the waveforms that cause the magnetic fields, operating in unison, to deflect the electron beam downward and across the screen in an orderly fashion. In the absence of any outside influence, when you first turn on the television, this oscillator will start up and quickly assume steady-state operation without regard for the information being broadcast by the TV station. The effect might be that the video information that made up part of the right side of the transmitted picture would be drawing a picture on the left side of your TV screen. The result would be a confused and confusing picture.

By the same token, if the vertical section of your television is bending the electron beam down toward the bottom of your TV screen when the TV station is transmitting the top of the picture, you're going to have a strange-looking picture.

The horizontal and vertical oscillators in your set have to be oscillating precisely in step with the broadcast signal. Otherwise, your television's horizontal and vertical sections wouldn't aim the electron beam at the correct point on the screen to paint the broadcast picture correctly. Your television's oscillators are kept in step with the broadcast signal by *synchronizing pulses* sent as part of the composite signal.

The circuits

Figure 2 is the general block diagram of a monochrome television. It contains a lot of information you don't need to understand the TV video broadcast signal. For starters, because we're only interested in the video, let's take out the speaker and the associated circuitry. Next, the power supply provides power for all of the circuits, but assuming they're working properly, they're essentially operating in the background and have no effect on the operation of the video circuits. Take out the power supply. That leaves a very simple block diagram.

The tuner selects the particular broadcast signal that's going to be doing its thing in your TV set from among the many signals being broadcast in the area, but that's all it does. The broadcast video signal has to be processed through the tuner in order to be used by the set, so we need to show this path.

That leaves only the IF amplifier, the video amplifier and the horizontal and vertical sections of the set. These devices cause the picture to be painted on the screen, and that's what we're concerned with here. This portion of the television's block diagram is shown in Figure 3.

The broadcast signal

Now that we have just the video portion of the television isolated, let's take a look at the broadcast signal to see how they operate together to produce a TV picture. Take a look at the accompanying sidebar, "The NTSC signal." That signal shows you much of the information you need to understand how the TV signal paints a picture on the screen.

Waveform A is a representation of a portion of the information needed to paint one field of video on the screen. Waveform B is a representation of a portion of the information needed to paint the second field of video on the screen, interlaced with the first field, to complete one frame of the picture.

Unfortunately, because the pulses in

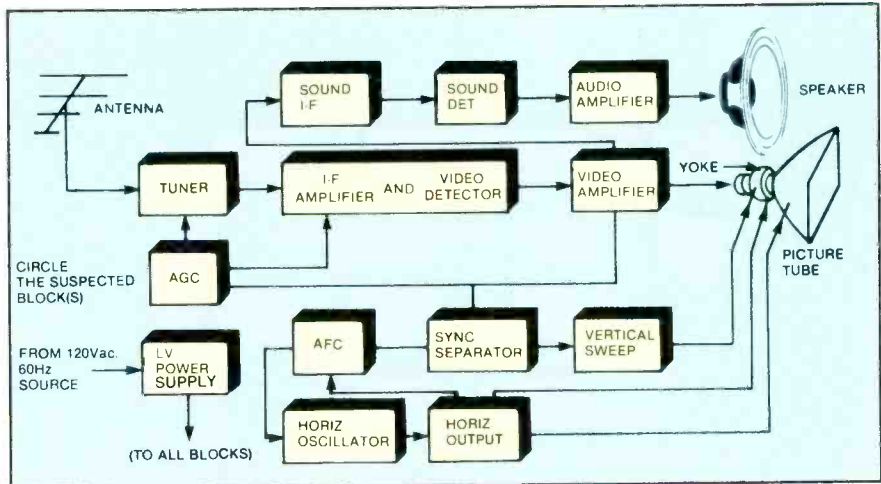

Figure 2. This block diagram of a monochrome TV set illustrates, among other things, the circuitry that is affected by the NTSC signal. The IF amplifiers amplify the tuned signal, the video circuits operate on the video portion of the signal, and the horizontal and vertical deflection circuits are kept in synchronization with the broadcast signal through the application of the sync pulses.

the center take up so much space in the drawing, it's easy to assume that is where a lot of the business is taking place. Actually, that is all taking place while no information is being painted on the screen. Just before this interval,

the electron beam dot that paints the picture has reached the bottom center of the screen (the end of the first field). During that interval, called the *vertical blanking interval*, the electron beam dot is shut off (if everything is operating

PACESETTER PRODUCTIVITY

100 MHz TEK 2246A/2245A

Smart scopes, perfect setup! Tek sets the new, fast pace for frequent measurements with automatic front panel setup. Nonvolatile memory for up to 20 front-panel setups (2246A). Time and voltage cursors. Exclusive SmartCursor™ track waveform changes for voltage measurements. All backed by Tek's 3-year warranty.

NEW

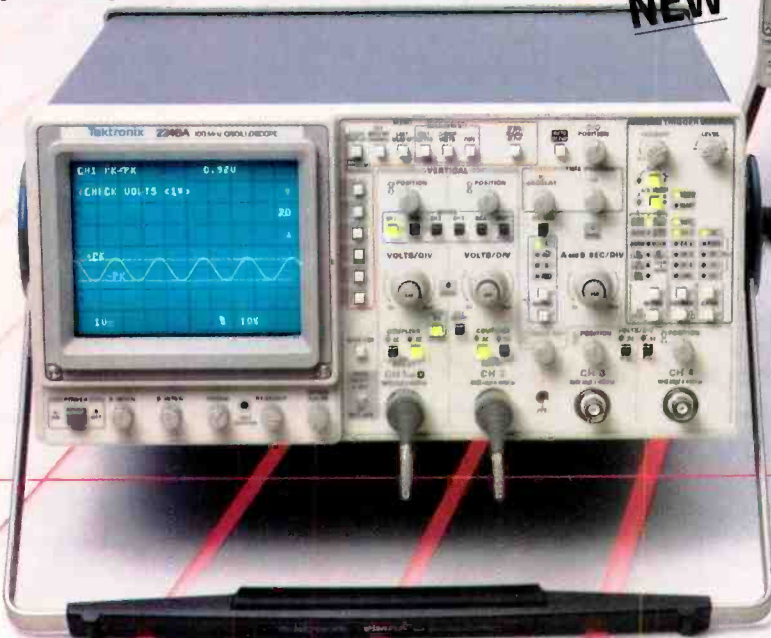

Call Tek direct
for PaceSetter specs!
1-800-426-2200

Prices subject to change without notice.

Copyright ©1988, Tektronix, Inc. All rights reserved. TTA 906-A

Tektronix
COMMITTED TO EXCELLENCE

Circle (9) on Reply Card

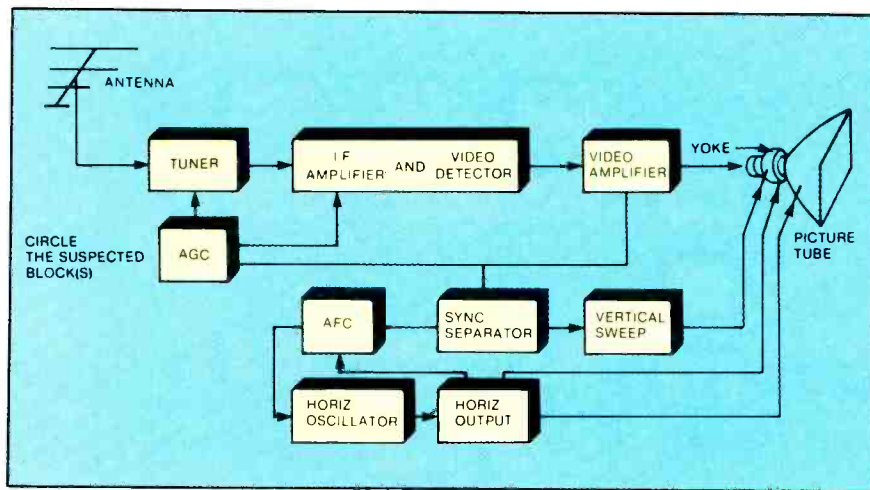

Figure 3. To understand the video and deflection circuits, it helps to emphasize them by eliminating the remainder of the TV circuits, shown here. Keep in mind, however, that in the real world any of the circuits we have left out of this reduced block diagram may cause video or horizontal or vertical problems.

correctly). At the same time, the magnetic fields produced by the horizontal and vertical windings are being changed so that, when the electron beam is turned on again, it will be at the top center of the screen, ready to start the

second field of video. It's as if you've turned off the flow of water in the hose nozzle and aimed the nozzle back up to the top of the screen.

I won't go into detail about why all of those pulses are there, but here's

what's happening in a general way: The vertical sync pulse (which looks like six separate pulses but is actually one pulse divided into six segments) is there to keep the frequency of the television's vertical oscillator in step with the vertical frequency of the transmitting station. (At this point the television's oscillator is entering a signal into the vertical circuits to move the dot back to the top of the screen.)

The equalizing pulses are there for two reasons—to maintain the distance between lines of video so that the two fields don't overlap, and to discharge the integrator capacitor (the device that passes the low-frequency vertical pulses and blocks the higher frequency horizontal pulses).

Those six horizontal sync pulses in a row then keep the horizontal oscillator on frequency while waiting for the next field of video information to begin.

Interpreting the NTSC signal waveform drawing

One of the reasons people have trouble understanding the NTSC waveform

ATTENTION CAMERA TECHS!

Equipment you need at prices you can afford!

\$688



Model TR100 CB Camera Light Box with transparencies

- Stainless steel
- (2) 3200⁰ Kelvin Lamps (meets mfr. spec.)
- 7-Bar color transparency
- 11-step gray scale transparency
- Transparencies mounted in acrylic with optical scratch-resistant surface.
- 1 year conditional guarantee

(313) 939-2740

Fax #(313) 939-6040

TRONIX inc.

31148 Lund, Warren, MI 48093

The method most manufacturers recommend

Circle (10) on Reply Card

NESDA Computer Group

COMPUTER SALES AND SERVICE DEALERS
WORKING TOGETHER

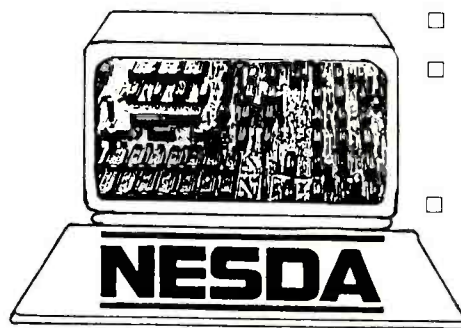

- Service training.
- Assistance in selecting in-house equipment and software.
- Specialized software for service management.

- Factory contacts for service literature and parts.
- Involvement in a stable and productive national trade association.

FOR MORE INFORMATION SEND BUSINESS CARD TO:
NESDA COMPUTER GROUP, 2708 WEST BERRY STREET
FORT WORTH, TEXAS 76109; PHONE (817) 921-9061

is that, because it would take a great deal of room to show the entire waveform, only a small portion of the waveform is shown. And as I mentioned, most of what is shown is the vertical blanking interval, giving the impression that it is the most important portion of the waveform or that most of the waveform looks like that.

That is not the case. Refer again to the sidebar that accompanies this article for a detailed explanation of what the NTSC waveform is doing.

Troubleshooting based on this information

Even a rudimentary understanding of how the broadcast signal and the circuits in the television interact can help hone troubleshooting procedures.

For example, let's say the trouble symptom in a TV set is a single horizontal line across the center of the screen. Because you know that the vertical deflection is caused by the vertical circuits, that is the first place to look. It probably doesn't matter precisely where you start, but a good place might be at the output

of the vertical driver if that's a convenient place to put your scope probe. That divides the vertical circuitry, so if you are getting a correct output here, move forward toward the yoke; if there is no signal here, move upstream until you find the source of the problem.

Or let's say you have a good raster but no picture. In this case, you can be confident that the vertical and horizontal circuits are operating properly and that the trouble is somewhere between the video detector and the CRT. In this case, you can take any of several approaches. One way to track down a missing-video problem is to start at the video detector and work forward to the picture tube to find out where the signal disappears. Another approach is to use a signal injector and work backward from the picture-tube video inputs until you reach a point where the injected signal no longer produces a picture. The problem is then isolated to the components between this test point and the previous test point.

Of course, nothing is ever as simple as you would like it to be. Even a

thorough knowledge of the composite video signal and the circuits involved with its components won't solve every problem. In televisions with scan-derived power supplies, for example, what should be a simple horizontal problem might shut down the entire set, causing messy troubleshooting problems. An AGC circuit might be the cause of video problems.

Other problems may masquerade as deflection circuit or video problems. Remember we said at the outset to ignore the power supplies because we're going to assume that they're operating properly. You can do that for the purposes of an article and to emphasize the understanding of particular circuits in the television. You can't really do that in the real world. An incorrect power-supply voltage could cause problems that appear to be video or deflection problems.

Still, knowing more about the composite video signal and what happens to it within the TV circuits will go a long way toward helping you with your troubleshooting.

ES&T_{inc.}

PACESETTER PERFORMANCE

100 MHz TEK 2236/2235

100 MHz scope, counter, timer, DMM — just \$2795

The ultra-versatile Tek 2236 makes measuring everything from frequency, period and width to delay time and Δ time push-button easy — in addition to CRT display, you get digital readout display accurate to 0.001% and beyond. PaceSetter performance on a modest budget? Look at the 100 MHz, dual-trace Tek 2235 with the best of the basics — just \$1575!

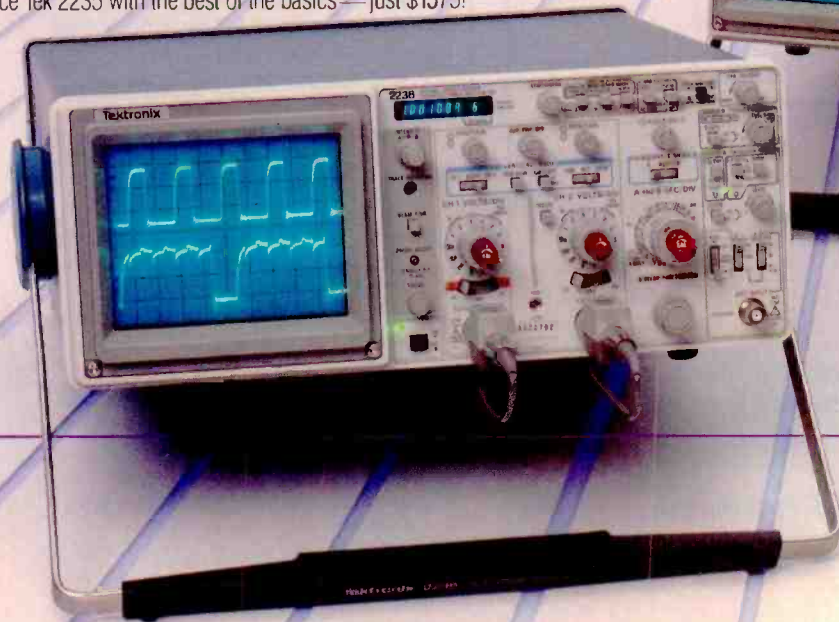

Call Tek direct
for PaceSetter specs!
1-800-426-2200

Prices subject to change without notice.

Copyright ©1988, Tektronix, Inc. All rights reserved. TTA 906-B

Tektronix
COMMITTED TO EXCELLENCE

Circle (11) on Reply Card

Coming Up in

ELECTRONIC

Servicing & Technology

May

Soldering/Desoldering Update

There are many new soldering/desoldering problems facing consumer electronic technicians these days. Find out what they are, and the equipment and techniques used to solve them.

Audio Servicing--Special Report

A special report on servicing audio equipment, including a troubleshooting quiz that leads you through a series of questions and answers, to a better understanding of the operation of audiotape recorder design and operation.

June

Test Equipment/Rental Test Equipment

You'll learn how logic analyzers can be used for digital circuit troubleshooting and analysis, and how to use the new generation of high technology/low cost digital storage oscilloscopes. Also, find out what you can obtain in test equipment through rental companies.

Servicing New Video/Audio Technology

VCRs, camcorders and digital compact discs represent the ultimate in current consumer electronics technology. They also present advanced technology problems for the people who must service them. Find out how to understand this "new technology" operation, and how to troubleshoot it when it malfunctions.

July

ESD Damage Protection

ES&T gives precautions that a technician should take before working on any modern consumer electronic circuits to avoid causing ESD damage.

Troubleshooting Tips

Here's a collection of troubleshooting tips, tricks and procedures for the servicing technician. Included are some tried and true oldies, and a few new ones.

Plus ES&T's Regular Monthly Departments

SYMCURE/ Troubleshooting Tips guidelines

ES&T is now paying \$60 per page (six different cases of symptoms and their solutions) for accepted Symcure submissions.

The term *Symcure* is a contraction of two words: symptom/cure. Problems that are published in the Symcure department are those that have occurred more than once.

This is the kind of problem you can solve without even a second thought because you've already seen so many of that particular brand and model of set with those symptoms; in almost every case, it will be the same component that fails or the same solder joint that opens.

It is preferred that you submit six or seven symptoms and cures for a single TV model.

ES&T is also paying \$25 per item for accepted Troubleshooting Tips.

A Troubleshooting Tip describes a procedure used to diagnose, isolate and correct an actual instance of a specific problem in a specific piece of equipment. Its value, however, lies in the general methods described.

A good Troubleshooting Tip has the following elements:

- It should be a relatively uncommon problem.
- The diagnosis and repair should not be obvious and should present something of a challenge to a competent technician.
- It should include a detailed, step-by-step description of why you suspected the cause of the problem and how you confirmed your suspicions—anything that caused you to follow a false trail also should be included.
- It should describe how the repair was performed and any precautions about the possibility of damage to the set or injury to the servicer.

For Symcures and Troubleshooting Tips, please also include:

- the manufacturer's name;
- the model and chassis number;
- the Sams Photofact number; and
- a sketch of the schematic area where the fault was found. (Include a major component such as a transformer or transistor to provide a landmark for the ES&T staff.)

Full-line catalog

Parts Express has introduced its 1988 full-line catalog of VCR parts, speakers, semiconductors, CATV products, tools, hardware, computer accessories, chemicals, cable, test equipment and more. The company features same-day shipping and a "no-risk" ordering policy.

Circle (125) on Reply Card

Tools and test equipment catalog

HMC is offering a fully illustrated buyers' guide of tools, test equipment and supplies, including tool kits, soldering/desoldering systems, lamps and magnifiers, antistatic products, wire-prep equipment and hand tools.

Circle (126) on Reply Card

Test, repair equipment catalog

The 1988 catalog from *Contact East* offers products for testing, repairing and assembling electronic equipment, including test instruments, hand tools, static protection supplies, adhesives,

soldering supplies, wire and cable aids, inspection aids, EPROM programmers, telecom/datacom instruments, power supplies and tool kits.

Circle (127) on Reply Card

Tool and tool-kit catalog

Techni-Tool's 240-page catalog number 34 contains more than 16,000 items from more than 850 manufacturers, offering tools and supplies for electromechanical assembly and maintenance, electronics, telecommunications, field service and computer maintenance, plus a line of static-control and clean-room items.

Circle (128) on Reply Card

Test and instrumentation guide

United States Instrument Rentals has published its 400-page 1988/1989 "Product Guide." The guide provides more than 5,000 different models from more than 100 manufacturers. Among the products listed are analyzers, CAE/CAD equipment, generators, meters, record-

ers, oscilloscopes and more.

Circle (129) on Reply Card

Electronics components catalog

This 184-page catalog from *Mouser Electronics* offers 16,000 items, including electronics components, knobs, speakers, hardware, tools, test equipment, cabinets, delay lines, crystals, soldering equipment, ICs, chemicals, antennas, microprocessors and more.

Circle (130) on Reply Card

Test instrumentation catalog

RAG Electronics is offering a product selection guide for its complete line of off-the-shelf electronic test instrumentation. Ten instrument categories are included: ac power sources, dc power supplies, analyzers, environmental chambers, generators, microwave instrumentation, motor generators, oscilloscopes, power-disturbance equipment and TV/video instrumentation.

Circle (131) on Reply Card

ES&T_{INC.}

PACESETTER PRICE

50 MHz TEK 2210/2225

Best-of-class performance at

\$995/\$2195 Get the *PaceSetter* start in digital storage with Tek's NEW 50 MHz 2210. Featuring 20 MS/s per channel digitizing, 4K record length per channel plus familiar, full-bandwidth analog operation for just \$2195. And for pure and simple analog performance with unmatched economy, look at the popular, 2-channel Tek 2225—just \$995!

NEW 2210
20 MS/s per channel

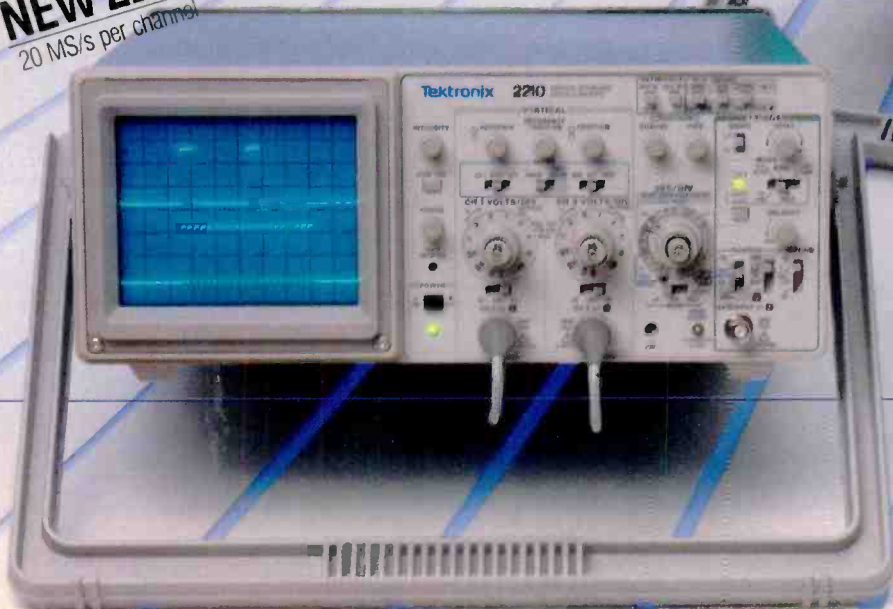

Call Tek direct
for PaceSetter specs!
1-800-426-2200

Prices subject to change without notice.

Copyright ©1988, Tektronix, Inc. All rights reserved. TTA 906-C

Tektronix
COMMITTED TO EXCELLENCE

Circle (12) on Reply Card

This SYMCURE is reprinted from Electronic Servicing magazine.

Chassis—Zenith 16DB12X
PHOTOFACT—1265-3

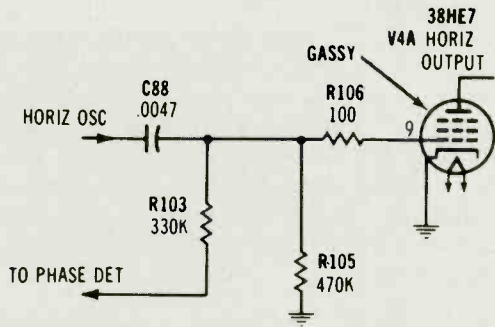

Symptom—Loses horiz lock after warmup
Cure—Replace 38HE7 output tube as a test for gas and positive grid

Chassis—Zenith 25FC45
PHOTOFACT—1453-3

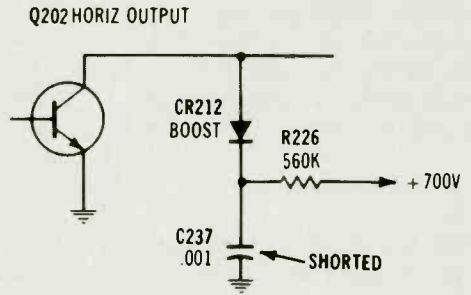

Symptom—No set-up horiz line; dim picture
Cure—Check C237, and replace it if shorted

Chassis—Zenith 9HB1X
PHOTOFACT—1611-2

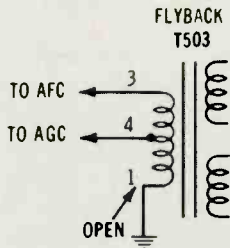

Symptom—Loss of contrast and locking
Cure—Check flyback, and replace if winding is open

Chassis—Zenith 25FC45
PHOTOFACT—1453-3

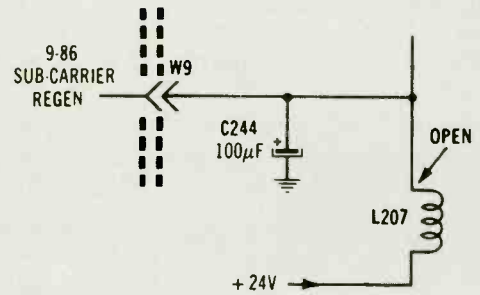

Symptom—Dim picture without color; video-output bases had less than normal positive voltage
Cure—Check L207, and replace it if open

Chassis—Zenith 13HC10
PHOTOFACT—1634-2

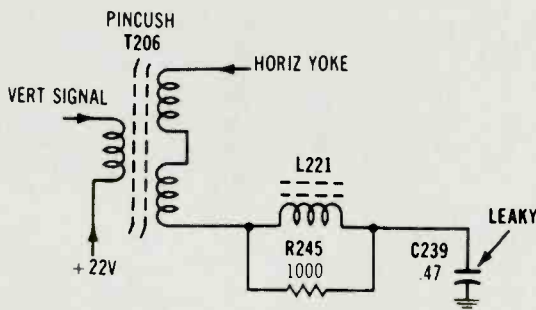

Symptom—No HV, RX234 open and Q204 shorted
Cure—Check C239, and replace it if shorted

Chassis—Zenith 19ED45
PHOTOFACT—1377-3

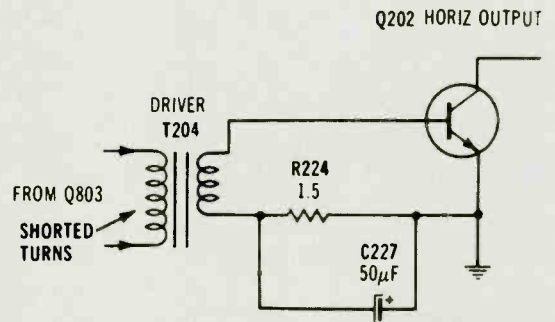

Symptom—Intermittent horiz foldover at right edge
Cure—Check T204, and replace if primary has erratic low ohms reading

With Instant Access, GE/RCA brings to the screen a world of replacement parts.

Now appearing at participating GE/RCA Distributors across the country is a new, highly efficient computerized replacement parts service called **Instant Access**.

With direct access to our main computer, a distributor can now learn the availability, pricing, and cross-referencing of whatever part you need, quickly and accurately.

Our massive inventory provides you with instant access to consumer parts, SK and MRO devices, broadcast parts, picture tubes, receiving tubes, electro-optics and devices, video accessories and video tape.

A precise cross-reference index automatically converts all leading industry

numbers for solid state devices (including MRO), and electro-optics and devices, into corresponding RCA part numbers. As well as converting RCA drawing numbers into RCA stock numbers for Consumer Electronics replacement parts.

Next time you need a replacement part in a hurry, look into

Instant Access.

You can even specify delivery—in less than twenty-four hours if necessary. To find the participating **Instant Access** distributor nearest you, write: Sales Promotion Services, Distributor and Special Products, 2000 Clements Bridge Road, Deptford, NJ 08096-2088.



Circle (13) on Reply Card

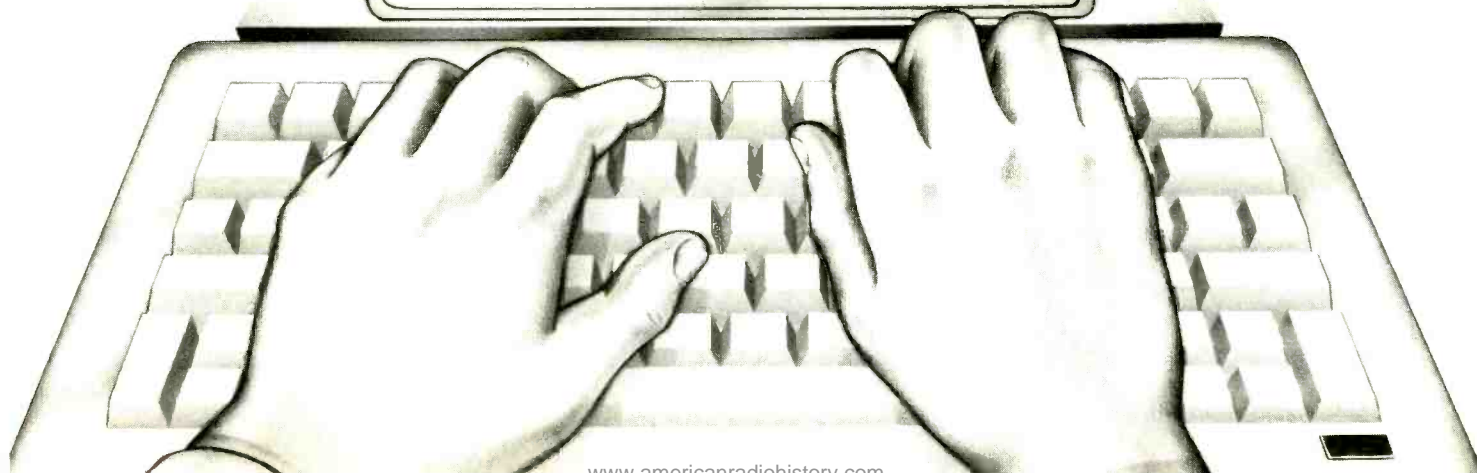
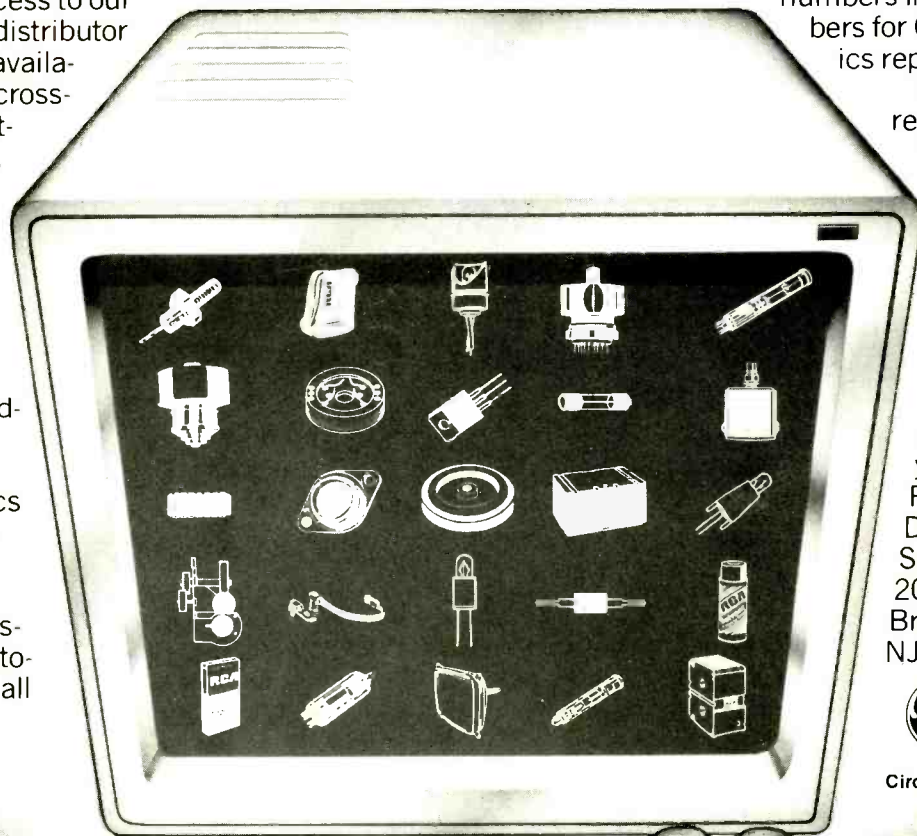

Test your electronics knowledge

By Sam Wilson

1. In Figure A, the voltmeter is used to determine whether there are shorted turns or an unbalanced condition. Which type of voltmeter should be used?

- A. ac
- B. dc

2. Could you get the same information by taking an oscilloscope reading across R? _____

3. A technician very carefully measures the primary resistance of the power transformer (disconnected

from the circuit) in Figure A. He finds that it is 77. He then carefully measures the secondary resistance and finds it to be 154. Using these values, can you determine the transformer turns ratio? _____

4. Two sine-wave frequencies (A and B) are delivered to a very linear (Class A) amplifier. The output of the amplifier has the following frequencies: A, B, A+B and A-B. Which of the following is true?

- A. The amplifier did not pass the linearity test.
- B. The output is normal for a linear (Class A) amplifier.

5. What is the third harmonic of a 75kHz, pure sine wave? _____

6. Using the lissajous method, you compare the input and output sine-wave voltages of a very linear Class A amplifier. What pattern should you get? _____

7. To make a very precise resistance measurement of a thermistor, you would use one of the following:

- A. an ohmmeter
- B. a Wheatstone bridge
- C. some other method

8. A certain single-stage amplifier circuit is used to convert dc to ac. What is the name of the circuit?

9. You want to compare two signals with frequencies of approximately 7Hz. You would use the dual-trace oscilloscope in which mode?

- A. alternate mode
- B. chop mode

10. The dc offset adjustment on a function generator allows you to set a dc voltage upon which the ac signal is superimposed. How can you be sure the sine wave is superimposed upon 0V?

Wilson is the electronics theory consultant for ES&T.

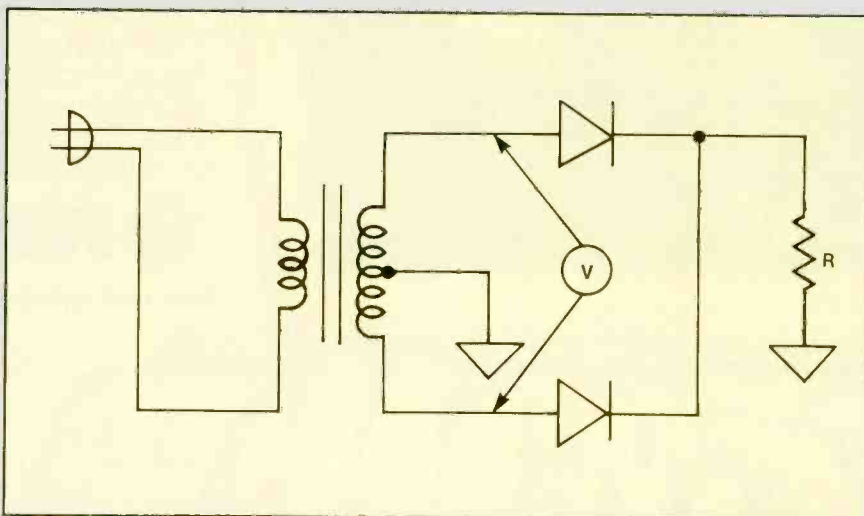
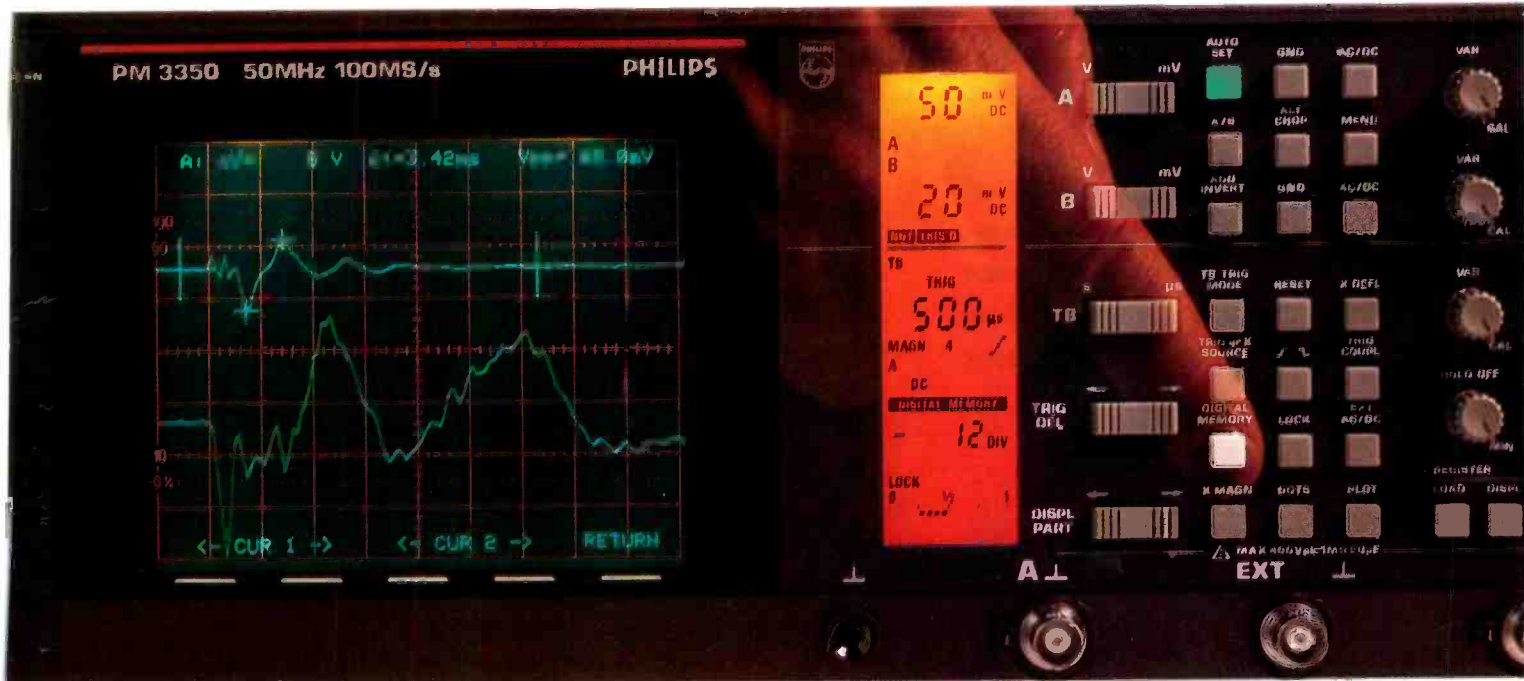

Figure A. Which type of voltmeter should be used to determine whether shorted turns or an unbalanced condition exist?

Answers are on page 55.



PHILIPS



Breakthrough! The first fast digital with analog for <\$4,000

It's here. The Philips PM 3350 Digital Storage Oscilloscope. High-speed digitizing plus full analog capabilities for half what the next-best DSO would cost you. Unbelievable!

BREAKTHROUGH PERFORMANCE

- 100 MS/s sampling speed on both channels simultaneously allows you to capture fast phenomena having low repetition rates—even single shots—with excellent resolution. A first in this price range!
- True 8-bit vertical resolution offers precise signal display and measurement.
- Deep reference memory lets you store and compare waveforms with ease.
- Plus, you get full, dual-trace 50 MHz real-time familiarity at the touch of a button.

FAST, CONFIDENT OPERATION

- **AUTOSET** automatically selects amplitude, timebase and triggering for error-free, instant display of any input signal on any channel—in both digital and analog modes!
- **LCD panel** serves as the text information center, offering clear, at-a-glance alphanumeric read-out of all instrument settings; saves screen area for uncluttered waveform viewing.
- **Cursors** supply instant voltage, timing, frequency, amplitude and risetime measurements.
- **Softkeys** grant you simple, direct access to over 40 different functions via on-screen menus.
- **IEEE-488 or RS 232 interface options**

for fast computer/controller hook-up, data transfer and printing hard copies.

COMPLETE SUPPORT

The Philips PM 3350 comes with a 3-year warranty and all the technical and service assistance you need. From Fluke—the people who believe that extraordinary technology deserves extraordinary support.

TEST THE DIFFERENCE

Call Fluke today at **800-44-FLUKE ext. 77**. And make a break with the past.

John Fluke Mfg. Co., Inc., P.O. Box C9090, M/S 250C,
Everett, WA 98206
U.S.: 206-356-5400 CANADA: 416-890-7600
OTHER COUNTRIES: 206-356-5500

© Copyright 1988 John Fluke Mfg. Co., Inc.
All rights reserved. Ad No. 0181-P3350



PM 3350 • 50 MHz • DIGITAL STORAGE SCOPE



Circle (14) on Reply Card

An oscilloscope update

By Conrad Persson



A lot of technicians remember the early days of oscilloscopes. To find the amplitude, you would attach the probes to the point you wanted to test, set the controls to a value that would give you some information about the signal being observed, count graticule divisions and subdivisions, then multiply by whatever scale factor you had set on your controls.

When you wanted to find the frequency of the signal, you would try to count horizontal scale divisions, then apply whatever scale factor was in effect. Of course, if this was an irregular signal, even finding the beginning and end of a cycle was a challenge.

And as if that weren't enough, back in those old days, when you were just setting up, with some scopes it was a game of hide-and-seek just to see if you could find the electron beam.

But that's not all. Once you had everything set up, it sometimes was difficult just to find out where you would trigger on the waveform. Even then it was often a challenge to make the waveform you had a picture of quit sliding across the screen.

I suppose, to use an automotive analogy, those were the good old days of the hand crank, hand choke, hand throttle, hand spark advance/retard, mechanical brakes, etc.

Times have changed

Times certainly have changed for the better where oscilloscopes are concerned. To continue with the automotive

Persson is editor of *ES&T*.

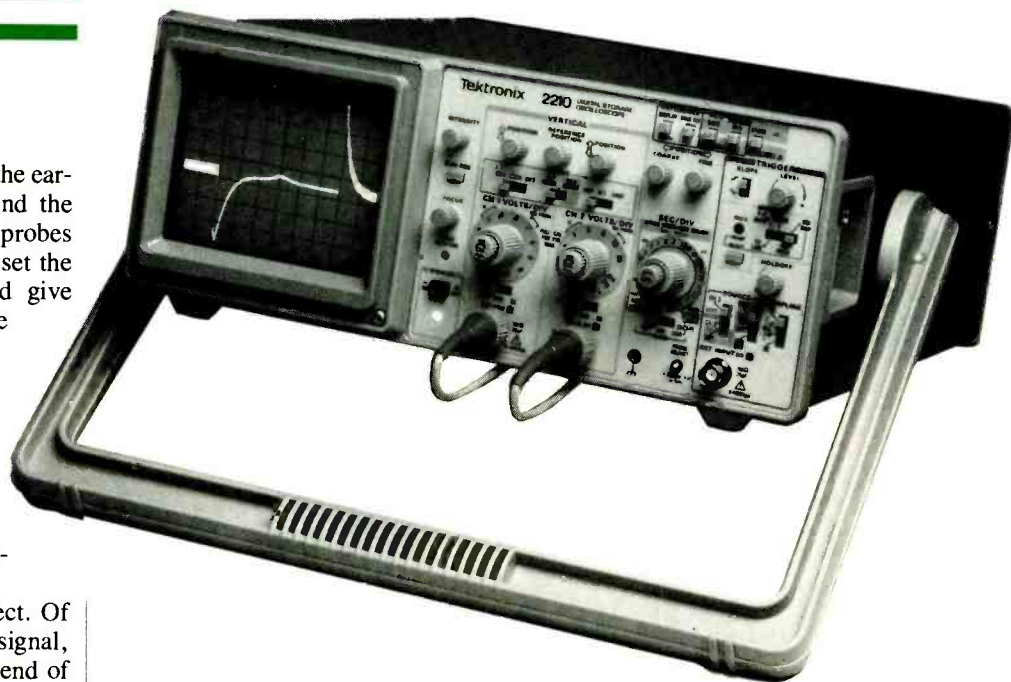

This oscilloscope, the model 2210, has a price tag of \$2,195. It features both analog and digital operation, 50MHz bandwidth, 20MS/s (megasamples per second) sampling and 8-bit vertical resolution. It can trigger on TV lines and fields, and it can store a waveform and compare it with another waveform on the screen. (Photo courtesy of Tektronix)

analogy, today is the day of electronic ignition, power steering and brakes, automatic transmission and more. In essence, we have reached the point where operation of an oscilloscope is no longer a mixture of science and magic that requires at least as much attention (and sometimes more) to the measurement process as to the operation of the equipment being tested.

Some of the things that these oscilloscopes will let you do, and with ease, are quite amazing if you haven't been exposed to them. For example, some of today's more advanced oscilloscopes have screen readout that, in addition to showing you the waveform, will read out directly the amplitude, period and frequency of the wave under study. Many have cursors that, placed at points of interest on the waveform, allow you to

read the voltage or time difference between the points.

Today's best digital scopes will allow you to do all of these things plus save a waveform (or more than one). This allows you to scrutinize them at your leisure or to compare them to other waveforms. Some will allow you to store desired values and then compare values encountered with those values stored, providing a quick go/no-go judgment.

You also can store several setups or programs, then select a program or sequence of programs to be used in testing a circuit.

And they get smaller

Microelectronics has done some incredible things. It has given us computers that you can put on your desk or on your lap, calculators as thin as a

Oscilloscope terminology

Cursor: A cursor is a lighted indicator on the face of an oscilloscope. The operator can place the cursor at any point on the waveform. If two cursors are placed on the waveform at selected points, the oscilloscope can read out the amplitude between the two points and/or the frequency and period of the waveform. I had a lot of fun putting together a definition for this one. Although I know exactly what a cursor is, I decided to look up its meaning. When I used the thesaurus on my computer's word processor, it ignored the "or" on the end and gave me several synonyms for the word "curse": bane, pestilence, execration, imprecation.

My dictionary wasn't much help either; it didn't have the word. So I went to an "encyclopedic dictionary" of electronic terms; no luck there either.

Either the word is so well understood by everyone that it doesn't even need to be in dictionaries, or it is so math/computer specific that it isn't found in more general references.

A cursor is a pointer or device used to mark a position. For those of you who remember the slide rule, the cursor was that piece of clear plastic on which there was a hairline that you would slide over the indicator to locate the answer. On a computer screen, the cursor is the little flashing box that shows you where the next letter will go when you press a key.

In the case of a modern oscilloscope, a cursor is an indicator that you can move to any location on the screen and use as a reference for a measurement. Let's take an amplitude measurement as an example. The old-fashioned way to make the measurement is to pick a point on the waveform, say a negative peak, then pick another point, say a positive peak, then count graticule divisions between these points, interpolating where necessary, then multiplying by whatever scale factor is selected by the controls at the moment. If you were very careful, you might be pretty close.

With a modern scope, when you've decided the two points between which you want to make a measurement, you manipulate the controls to place a cursor at each of those points, then push another button. The amplitude is read out numerically on the screen, taking into account the scale factor that you're using at the time.

You can also place cursors at the beginning and end of a cycle. Pushing the ap-

propriate buttons will give you a readout of both frequency and period. You can forget scale factors, division, powers of 10. The scope does all of that for you.

Sampling rate: Unlike an analog oscilloscope, which simply amplifies (or attenuates) the input signal and then displays it on the screen, a digital oscilloscope measures the waveform amplitude at regular intervals. It then converts this numerical information into a digital value, stores it temporarily, manipulates it, converts the digital information back to an analog signal and displays it on the screen. The number of times per second that the scope measures (samples) the signal of interest is the sampling rate.

The sampling rate is limited by the capabilities of the microcomputer and other circuitry in the scope; in turn, it limits the frequency of the signal that can be acquired and displayed by the scope.

Resolution: The resolution of a digital storage oscilloscope is defined by the number of bits. A common value for this parameter is seven bits. This value refers to the number of binary digits (bits) into which the waveform can be divided. It also determines how closely the stored and displayed waveform can be made to follow the original input waveform. If relatively few bits are used, the waveform looks like a series of steps. The greater the number of bits, the smoother the waveform looks.

Let's see what that means. When the waveform is at its zero value, the seven bits with which we can represent the value would be 0000000. Then, when the waveform is at its maximum value, it would be represented by the number 1111111. Any value in between would be represented by some combination of 1's and 0's.

The seven bits of resolution gives a total of 2^7 discrete values, or 128 values that can be represented by the digital numbers. For a concrete example, take a sine-wave voltage of $300V_{p-p}$. The smallest fraction that this could be divided into with 128 steps is $300/128$ or about 2.3V. This doesn't sound terribly accurate, but looked at from another point of view, it's not too bad. If you were displaying the signal full-height on a 5-inch scope screen, that 2.3V of signal would occupy only $5/128$ or about 0.04 inches of vertical distance on the screen.



The Scout SC01 DSO (digital-storage oscilloscope) isn't much larger than a hand-held DMM. It weighs 25 ounces and features two input channels, 7-bit resolution and waveform storage. It also provides the functions of a DMM, a frequency counter and a signal computer. Cost: \$1,995. (Photo courtesy of Dolch American Instruments)

DISCOUNT

**THATS OUR MOTTO
INCREASE YOUR PROFITS
BY JUMPING ON THE
RNJ ELECTRONICS
BANDWAGON**

The Most Complete One Stop
Catalog in the Industry.
Quality Products & Service You Can
Count On

YOUR DISCOUNTED SOURCE FOR

- Test Equipment
- Antennas
- Amplifiers
- Chemicals
- Tools & Soldering Equip.
- Background Sound
- VCR Parts & Accessories
- Semiconductors
- Triplers & Flybacks
- Speakers
- Intercoms

**CALL FOR
FREE
CATALOG**

800-645-5833
516-226-2700



RNJ ELECTRONICS, INC.

805 ALBANY AVENUE • P.O. BOX 528
LINDENHURST, NEW YORK 11757

Circle (15) on Reply Card

INTRODUCTION TO VCR REPAIR ON VHS VIDEO TAPE

This new release by Ucando explains how the VCR works from the tuner to the RF modulator.

YOU WILL LEARN:

- How the chroma signal is processed
- How the luminance signal is processed
- How the audio signal is processed
- How the video drum servo works
- How the capstan servo works
- How the control head works
- How to clean the tape path
- Professional troubleshooting techniques

SAVE TIME AND MONEY

After viewing this program you will have a better understanding of how the VHS VCR functions. **To save time and money on your VCR repairs order your own VHS VCR tape now!** Simply call (513) 548-6113 and have your Master Card or Visa ready.

Price \$29.95 + \$3.00 Postage

Please allow 2-4 weeks for delivery.

10 Day Money Back Guarantee!



VCR EDUCATIONAL
PRODUCTS CO.
P.O. BOX 386
GREENVILLE, OHIO 45331

Circle (16) on Reply Card

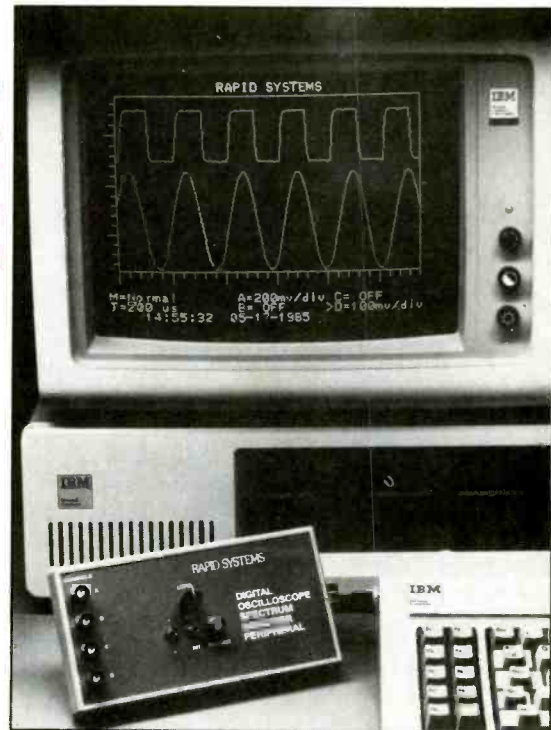

This peripheral for the IBM PC, XT or AT turns the computer into a device that performs the functions of a 250kHz digital oscilloscope, FFT spectrum analyzer and data logger. Cost for the peripheral and the software to run it is \$995. (Photo courtesy of Rapid Systems)

credit card and televisions that you can practically put in your shirt pocket. Not too long ago, they even came up with an oscilloscope you could hold in your hand. Now there is a hand-held, digital-storage oscilloscope that is also a multimeter, a counter and a signal computer.

The personal-computer oscilloscope

Another recent advancement in oscilloscopes is a peripheral for the personal computer. This is a device that has as inputs BNC connectors just like those on the face of the scope. Its output goes to the input of the computer. You basically use one of these just as you would an oscilloscope. The computer's monitor provides the oscilloscope display screen.

I have a Commodore 64 at home, so I borrowed an oscilloscope peripheral device for it from Rapid Systems in Seattle. Of course, the capability of the PC-based oscilloscope will greatly depend on the computer it is designed to work with. Although the 64 is a dynamite machine for its class, it is limited in size and speed. Because of this limitation, as an oscilloscope it is limited in bandwidth and useless as a TV servicing device. It is, however, of interest as a low-bandwidth, general-purpose device, useful for some audio work, and just fun for experimenting.

You don't have to know much of anything about the computer to use the PC-based scope. You simply place the program diskette in the disk drive and type in the necessary command for the computer to read the disk. In the case of the 64, I simply had to type in a brief load instruction, and the program loaded. Once the program had loaded, a simulated scope face appeared on the monitor screen. Connecting the probe to the circuit yielded an acceptable representation of the signal on the screen.

Of greatest interest was the capability to store and retrieve the waveform. I needed only to put a blank, formatted disk into the disk drive, press a few keys on the computer keyboard, and the waveform was stored on the disk. Five minutes later, or five years later, I could load the oscilloscope program, put that disk back into the disk drive and call up that waveform. This capability also implies the capability to transmit that waveform via modem and phone lines to a distant location, or to print out a copy in the event that a technician needs to enlist help in interpreting it.

This same company and others also make oscilloscope peripherals for more powerful computers like the IBM PC. These peripherals turn those computers into oscilloscopes with greater bandwidth, some of which are serious tools for electronic design and servicing.

ES&T

Quick and Accurate LAN Measurements: \$2,495*

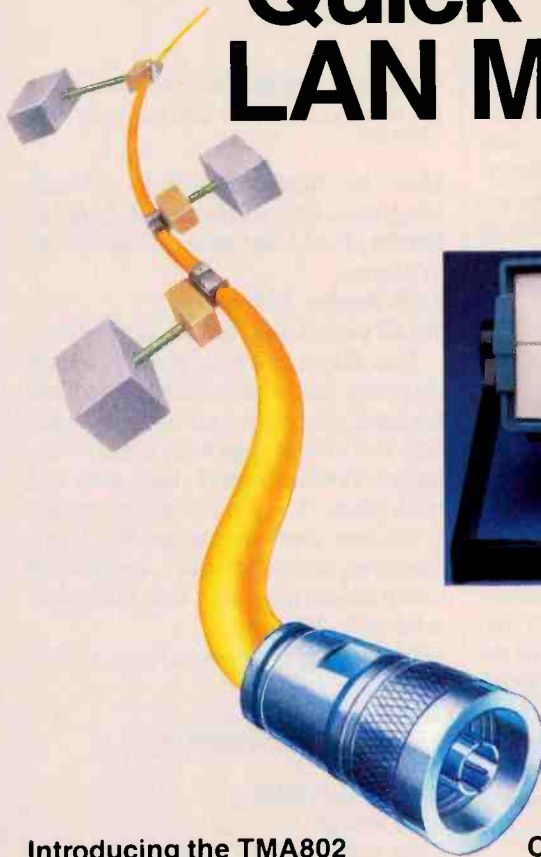

Introducing the TMA802 Media Analyzer

The Tek TMA802 is an easy-to-use, cost-effective tool that can quickly and accurately evaluate the

Compatible with the entire family of IEEE 802 LANs, the TMA802 supports Ethernet, Cheapernet, Starlan, MAP, Token Bus and IBM Token Ring networks.

powerful modes:

Idle Mode, for quick status reports.

Probe Mode, for a detailed work view including receivers and transmitter via a 50MHz oscilloscope.

Monitor Mode, for accurate reports of cable traffic load independent of protocol or vendor.

Portable and efficient, the TMA802 is capable of testing coaxial, twisted-pair based LANs, report distance in feet or meters, or roundtrip propagation delay in microseconds.

Rugged and reliable, the 8-pound TMA802 is portable, battery-operated, and built to Tektronix standards which assure operation in the field under a wide range of environmental conditions.

For a demonstration or more information, contact your nearest Tektronix Sales Office, or the Communications Network Analyzers Division, Tektronix, Inc.,

625 S.E. Salmon,
Redmond, OR 97756, USA.

Telephone 503/923-4415.
*U.S. List Price



Circle (29) on Reply Card

Tektronix
COMMITTED TO EXCELLENCE

Copyright © Tektronix, Inc. All rights reserved. PCA-329 1087

Commodore 128 Troubleshooting & Repair, by John Heilborn; Howard W. Sams; 160 pages; \$19.95.

This step-by-step "how-to" manual shows proper care and routine maintenance for the Commodore 128. The guide covers diagnostic techniques, operation, hardware, preventive maintenance, required tools, data sheets, assembly and disassembly instructions and a comprehensive glossary.

Howard W. Sams, 4300 W. 62nd St., Indianapolis, IN 46268; 800-428-SAMS.

Fundamentals of Automotive Electronics, by V.A.W. Hillier; Hutchinson Education; 324 pages \$13.95, paperback.

According to the author, servicers who want to repair electronic equipment used in the automotive industry must have special training because the electronic applications also involve the mechanical systems. This primer in automotive electronics introduces magnetic, electrical and mechanical principles and covers general maintenance and fault diagnosis for various electronic devices. Topics covered include circuits and systems, batteries, starter systems, combustion and ignition, sensors, engine fuelling and more.

Longwood Publishing Group, 27 S. Main St., Wolfeboro, NH 03894-2069.

Turbo Prolog Primer, Revised edition, by Dan Shafer; Howard W. Sams; 350 pages; \$19.95.

This introductory text examines the new Version 1.1 of Turbo prolog and helps programmers expand their knowledge of artificial intelligence and expert systems. The book examines the elements of the language and shows how programming in Turbo Prolog differs from programming in other languages. It also features the newly released Turbo Prolog Toolbox.

Howard W. Sams, 4300 W. 62nd St., Indianapolis, IN 46268; 800-428-SAMS.

Turbo C Programming for the IBM, by Robert Lafore; Howard W. Sams; 608 pages; \$22.95.

This tutorial is based on Borland's new Turbo C compiler. The author

begins with the fundamentals of C programming, followed by intermediate concepts of arrays and pointers, data structures and the use of the C library. The text also addresses advanced topics, such as assembly language interfacing using DOS and ROM routines, all in the context of the IBM programming environment.

Howard W. Sams, 4300 W. 62nd St., Indianapolis, IN 46268; 800-428-SAMS.

500 Electronic IC Circuits With Practical Applications, by James A. Whitson; TAB Books; 352 pages; \$18.60 paperback, \$28.95 hardbound.

This book provides the practical information necessary to take electronic circuit diagrams and convert them into working electronic devices. Many of the circuits are accompanied by descriptive text and other technical data. The book contains more than 600 detailed illustrations and tables, an appendix of electronics parts and component suppliers, and a complete index of circuits and components.

TAB Books, P.O. Box 40, Blue Ridge Summit, PA 17214; 717-794-2191.

The CET Study Guide, 2nd edition, by Sam Wilson; TAB Books; 322 pages; \$14.60 paperback, \$21.95 hardbound.

This updated study guide offers a comprehensive review for passing the Associate-level and Journeyman-level (Consumer Electronics specialty) CET exams. To help readers gauge their comprehension, every chapter concludes with a review and with practice questions (with answers). Two complete, 75-question tests are included at the end of the book. Included throughout the study guide are hints for avoiding careless errors.

TAB Books, P.O. Box 40, Blue Ridge Summit, PA 17214; 717-794-2191.

Basic Electronics Course, 2nd edition, by Norman H. Crowhurst; TAB Books; 440 pages; \$14.60 paperback, \$23.95 hardbound.

Advanced electronics concepts are not as difficult to grasp if you understand the fundamentals. This book explains those fundamentals, discussing electronics theory such as electron flow, magnetic fields and the concepts of

resistance, voltage and current.

TAB Books, P.O. Box 40, Blue Ridge Summit, PA 17214; 717-794-2191.

How to Read Electronic Circuit Diagrams, 2nd edition, by Robert M. Brown, Paul Lawrence and James A. Whitson;

TAB Books; 224 pages; \$12.60 paperback, \$20.95 hardbound.

This introduction to reading circuit diagrams has been updated to include the latest information on computer symbols and circuit diagrams, digital electronics, Boolean algebra, logic gates and truth tables. The guide teaches readers to become proficient at reading block diagrams, exploded views, mechanical construction diagrams and electronic schematic diagrams.

TAB Books, P.O. Box 40, Blue Ridge Summit, PA 17214; 717-794-2191.

PHOTOFAC

TV RECEIVERS

EMERSON

2568-3 . ECR138A, ECR138 (SUFFIX C/D/E)

GENERAL ELECTRIC

2556-1 8-1900A01/10A01/30A01/31A01/38A01 (CH. 19MK-1)
2562-1 8-2670A01/71A01/79A01/80A01/82A01 (CH. X126A)
2567-1 8-2789A01, 8-2790A01

JC PENNEY

2552-1 685-2137-00
2554-1 685-2140-00
2555-1 685-2134-00

JVC

2557-1 CI336

MITSUBISHI

2553-1 CS2051R/52R/53R

PANASONIC

2558-1 CTH-1300 (CH. NMX-L4/PI13)
2560-1 CTJ-1941R/42R, PC-20P42R/49R/49RS
2566-1 CTJ-1922 (CH. LDP139)

QUASAR

2551-1 TP2156BH/BL/BR/BU/H/L/R/U/X/Y (CH. ALGC145)
2554-2 TT6267AW

(CH. ALDC147)
 2555-2 TP3958YQ/58YW/59YQ
 (CH. ADC137, ALDC137)
 2569-1 WT5931BW/BW1,
 YWT5931BW
 2571-1 TT6288BE/BH/BV,
 YTT6288BE

RCA
 2563-1 FLR510W/515E/618W,
 GLR660T/62T/64T/70P/
 72P/74P/78H/80T/82E/82T/
 84H/84L/88P (CH.
 CTC120D SUBI)
 2564-1 EMR350W/50E/55W/
 58AR/58WR/59ER
 (CH. CTC135A)

SEARS
 2553-2 562.40801650
 2556-2 562-40651650
 2558-2 564.40843650/51
 2559-1 564.42690550/51,
 564.42751650
 2560-2 564.40844750
 2562-2 564.48012750
 2568-2 564.48871650/51,
 564.48771650/51
 2569-2 564.42451650/51/52/53
 2570-1 564.41401550, 564.41411550,
 564.41412550
 2571-2 564.48890650/51/52

SHARP
 2552-2 . . . 13LV56BK/BL/GR/P/W/Y,
 13LV56ABK/ABL/
 AGR/AP/AW/AY
 2557-2 20LP76

SONY
 2564-2 KV-1380R
 (CH. SCC-754D-A)
 2565-1 KV-2040R
 (CH. SCC-A05C-A)
 2566-2 KV-27DS1, KV-27DS2
 (CH. SCC-A49B-A/C-A,
 SCC-754S-A/T-A)

SYLVANIA
 2561-1 RGHI48SL01

TOSHIBA
 2563-2 CX1467/67C
 (CH. TAC8790/95)

ZENITH
 2551-2 C1908W4/10B/12W1/92W1,
 C3918W/30W/72HW,H1952A/
 52W/53A/53W,SC1907W/
 11W,SC3931W,V3912W
 2559-2 SC1327W/31Y,
 SC3321S/61S

2561-2 C1920W1,C3960S,
 SC1923W/95W,SC3921S/
 43W/61S/73H
 2565-2 SBI923W/23WC/23X/
 23XC/23YC/27W/27X/65W/
 65WK/97W, SB3933W/33WC/
 35W/35WC/53W, SV3931W

2570-2 C1312W, C1382W
MONITORS
IBM
 2567-2 5154001
MAGNAVOX
 2568-1 7BM613074G
ES&T



KIK

Factory Direct
800-545-8784

Celebrating our 10th Year in U.S.A. . . .

Proven Quality . . .

Factory Direct Prices!



COS 5100: 100 MHz

- 3 Channel, 8 Trace
- P-P level-lock auto-trigger
- Delayed Sweep

Now Only
\$999.00

COS 5042TM, 40 MHz \$779.00

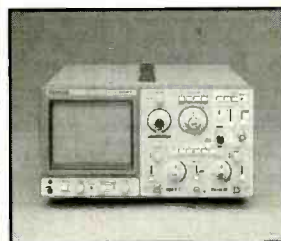

COS 5041TM

- 40 MHz, Delayed Sweep
- 2 Channel
- Ch 1 Signal Output

\$669.00

COS 5021TM

- 20 MHz, Delayed Sweep
- 2 Channel
- Ch 1 Signal Output

\$489.00

COS 5040TM

- 40 MHz
- 2 Channel
- CH 1 Signal Output

\$639.00

255 Frequency Counter:
 150 MHz **\$299.00**

FC01130 Frequency
 Counter: 1GHz **\$739.00**

677D Wow and Flutter
 Meter **\$949.00**

6701 Wow and Flutter
 Meter **\$999.00**

COS 5020TM

- 20 MHz
- 2 Channel
- CH 1 Signal Output

\$449.00

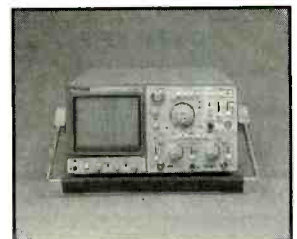

COS 5060TM

- 3 Channel, 8 Trace
- P-P level-lock auto-trigger
- Delayed Sweep

\$889.00



Add \$15 per unit shipping and handling.

(800) 545-8784

(213) 371-4662
 Collect CA & AK

Local Service Centers
 Nationwide

©Copyright Kikusui International Corp. 1988



Kikusui International Corp.
 19601 Mariner Avenue
 Torrance, CA 90503

Circle (30) on Reply Card

HITACHI SCOPES

15-25% Discount



V1060
100MHz
\$1375

V660 60MHz Dual Trace \$990
V422 40MHz Dual Trace \$699
V212 20MHz Dual Trace \$475

ELENCO PRODUCTS AT DISCOUNT PRICES!



\$498
MO-1252

Scopes

MO-1253 40MHz Dual Trace \$550
Delayed Sweep 12KV HV, More
MO-1252 35MHz Dual Trace \$498
MO-1251 20MHz Dual Trace \$349
w/ Two 1x, 10x 100MHz probes, manual
S-3000 10MHz fully calibrated \$239

GF-8016 Function Generator with Freq. Counter



\$239.95

Sine, Square, Triangle
Pulse, Ramp, .2 to 2MHz
Frequency .1 thru 10MHz

GF-8015 without Freq. Meter \$179

Digital Triple Power Supply

Model XP-765 \$239.95



0-20V @ 1A
0-20V @ 1A
5V @ 5A

Fully Regulated, Short Circuit Protected
with 2 Limit Cont. 3 Separate Supplies
XP-660 w/ Analog Meters \$169.95

Color Convergence Generator



SG-200

\$69.95

Finest in the industry
10 rock steady patterns

Digital LCR Meter

\$138.95

Model LC-1800

Measures
Inductors,
Capacitors,
Resistors



Multimeter with Cap. and Trans. Tester

\$59.95

Model CM-1500A

8 Functions
with Case



C&S Sales Inc., 1245 Rosewood
Deerfield, IL 60015 (312) 541-0710
800-292-7711 ASK FOR CATALOG

15 Day Money Back Guarantee
2 Year Limited Guarantee
Add 5% for Postage (\$10 max)
IL Res., 7% Tax



Circle (31) on Reply Card

Products

IC design spec guide

The 1988 *IC Master* from *Hearst Business Communications* is a 3-volume guide to IC design specifications. Volume 1 lists more than 80,000 standard ICs—including 10,000 new devices—grouped by basic category. It also includes a military parts list, a part-number index and an alternate-source directory that lists more than 92,000 current and discontinued devices. Volume 2 lists technical data from more than 575 manufacturers. Volume 3 is a new systems-level volume. Updates to the guide are issued in the spring and fall.

Circle (75) on Reply Card

Serial scanning switch

The model 232SSS serial scanning switch from *B&B Electronics* automatically scans two RS-232C serial ports waiting for data to be sent, allowing two computers to share a serial printer. If the switch is connected to one computer and the other computer tries to output, it will be kept in a busy state until the first computer is done. The switch comes with a 110Vac power supply.

Circle (76) on Reply Card

Miniscales

Mini-tool has introduced a line of precision miniscales used to quick-test hole sizes, pad sizes and line-width measurements. The instruments can be used with microscopes or loupes from about 5-40 magnification. Three models are available: the model #027, which has

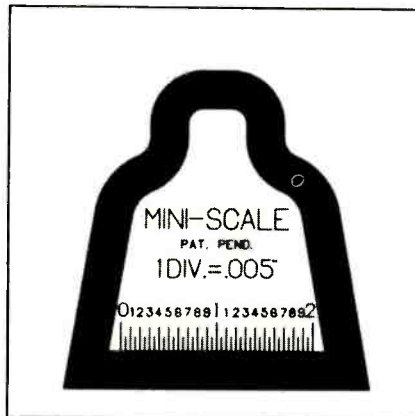

a 5mm range (0.1mm increments); the model #028, which has two ranges—a 5mm range (0.1mm increments) and a 0.200-inch range (0.005-inch increments); and the model #029, which has a 10mm range (0.1mm increments).

Circle (77) on Reply Card

Probe-style DMM

The AR-100 Maxi-Probe from *American Reliance* acts as an autoranging DMM that measures dc or ac voltage and resistance; a logic probe that works with both TTL and CMOS logic at up

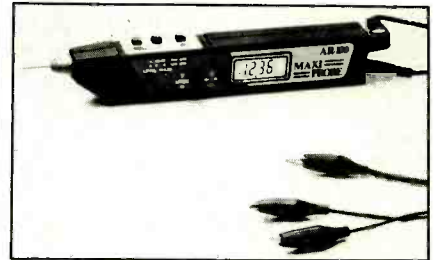

to 10MHz; and an audible continuity checker. Features include a data-hold feature, a removable ground lead and a diode test for reading the forward voltage drop of a rectifier. The DMM can be used with screw-on accessory tips.

Circle (78) on Reply Card

Laboratory power supplies

The PS732 series bench-top laboratory power supplies from *O.K. Industries* have dual 3½-digit display for simultaneous metering of current and voltage. Output controls provide 0.1% accuracy for voltage reading and 0.3% accuracy for current readings. The display provides resolution to 0.01V and 0.001A over the entire range.

Circle (79) on Reply Card

Data-acquisition peripheral

Rapid Systems has introduced the R414 data-acquisition peripheral for IBM PC/XT/AT and compatible computers. The peripheral includes all the hardware and software necessary to turn the PC into a 4-channel data-acquisition unit with selectable sample rates from 1kHz to 500kHz. The hardware also allows user-selectable gain from 10mV to 320V_{p-p} for 8-bit accuracy.

Circle (80) on Reply Card

Tool set

Jonard Industries has introduced a 20-piece precision tool set that measures 11"x6" and weighs 2 pounds (including tools). The kit includes a selection of pliers, screw drivers, tweezers, nut drivers and needle files, plus a soldering iron, a burnisher, a pin vice, a solder aid, an alignment tool and a solder core.

Circle (81) on Reply Card

Continued on page 50.



NEW TEMPERATURE SENSING SMD REWORK STATION O.K. Industries Inc. introduces a new closed loop thermocouple controlled rework station capable of removing and replacing large leaded and unleaded surface mount devices. Designated the ED-500, the unique temperature control protects both board and component during the entire rework cycle. The component is further protected by a stream of cool air during the reflow process. The ED-500 utilizes vacuum pickup for gentle component handling and localized hot gas heating to avoid thermal stress to adjacent areas. Maximum control is afforded by closed loop heat sensing, a timer function and board pre-heater. The heating head is easily movable in all directions, giving the operator unprecedented flexibility during rework. An optional stereo microscope increases placement accuracy and allows for close inspection of the rework.

Prices start as low as \$6495.00.
Contact: O.K. Industries Inc. 1-800-523-9667 (outside of N.Y.S.) or (914) 969-6800.

Circle (32) on Reply Card

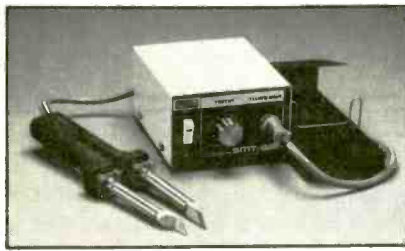

SMT-W2 SMD REMOVAL SYSTEM O.K. Industries introduces the SMT-W2, a hand-operated SMD removal tool. Featuring a variable temperature controller, tweezer-action handpiece, handpiece stand, and a wide variety of optional tips, the system affords an effective low-cost solution for SMD removal. The SMT-W2 tips have a high thermal capacity to support removal of the most demanding components. Dual 80W ceramic heating elements provide rapid heat recovery and

exceptional temperature stability. Additionally, the variable temperature controller enables the user to vary temperature over a range of 330°-740°F. A full range of tips are available including 5mm tips for resistors or capacitors, mini-flats for S01C's and right angle tips for PLCC's to 84 pins. Delivery is Ex-stock. List price is \$425.00. For more information contact: O.K. Industries Inc., 4 Executive Plaza, Yonkers, NY 10701, 1-800-523-0667 (In N.Y.S. call (914) 969-6800).

Circle (65) on Reply Card

Would you rather fight or switch?



O.K. INDUSTRIES SA-3 SOLDERING STATION The O.K. Industries SA-3 is a temperature controlled soldering station. This unit boasts a variable temperature control ranging from 210°-930°F, making the SA-3 a mandatory tool for all applications requiring maximum temperature flexibility and accuracy.

In addition, 3 wattage irons (30, 48, 60) are available to cover most every soldering application. Each iron comes equipped with grounded tips, making the SA-3 MOS and CMOS safe. Repair of this unit is made simple with the modular PCB design. Delivery is Ex-stock. List Price is \$105.00.

For more information, contact: O.K. Industries Inc., 4 Executive Plaza, Yonkers, NY 10701, 1-800-523-0667 (In N.Y.S. call (914) 969-6800).

Circle (63) on Reply Card



O.K. INDUSTRIES ADDS SOLDER/DESOLDER STATION TO CURRENT DESOLDER LINE UP O.K. Industries has introduced a new completely self-contained solder and desolder system. The SA-1200 is designed for multilayer board rework and repair. Its desolder handpiece has a powerful 65 watt heating element for extremely rapid heat recovery. The desolder handpiece has a high heat capacity, non-threaded tip which provides sufficient heat for boards with high thermal masses. The SA-1200 has a 24 volt, 48 watt variable temperature solder iron. The SA-1200 has a self-contained pump with quick rise vacuum, (21 inches/Hg), variable temperature control of 660°-880°F (desolder and solder), safe 24 volt handpieces, zero voltage heater switching. Additionally, the desolder handpiece, with its ergonomic pistol-grip design has hot air flow control for heat shrink tubing. The unit comes complete with tip cleaning sponge and tray, iron holder, non-burn Silicone rubber cord, separate lighted on/off power indicator and a full range of tip sizes.

The SA-1200 is available from stock and list price is \$495.00. For more information and the name of your local stocking distributor, contact: O.K. Industries Inc., 4 Executive Plaza, Yonkers, NY 10701, (914) 969-6800.

Circle (64) on Reply Card



O.K. Industries' full range of PC Board service tools eliminates costly board damage and wasted time by providing the right tool for the job. From IC insertion and extraction tools that help you remove or replace IC's quickly and safely to PC board fixtures that make repair or assembly easy. For everything you need to do the job right the first time call O.K. today.

800 523-0667

IN NEW YORK STATE DIAL (914) 969-6800

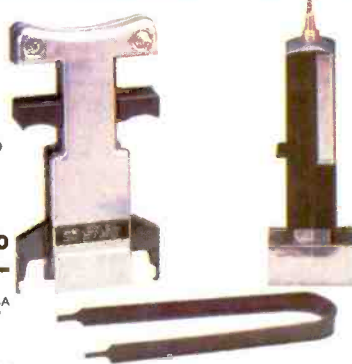

4 Executive Plaza, Yonkers, New York 10701 USA
Telex 125091 OK NYK Telex 232395 OK NY UR
Phone (914) 969-6800
Fax (914) 969-6650

Circle (66) on Reply Card

Capacitor and parts tester

Beckman Industrial has introduced the CAPT6, a multifunction capacitor and parts tester. The hand-held meter weighs 8.8 ounces and features 0.5% accuracy. The tester has 24 ranges covering capacitance testing (200pF through 20,000F), resistance (200 through 20M), dedicated diode and LED testing, battery testing under load conditions,

and NPN and PNP transistor testing of both gain and leakage current.

Circle (82) on Reply Card

Oscilloscope

The model 1020 20MHz oscilloscope from Leader Instruments has an ergonomic front panel, 0.5mV sensitivity and an 8x10cm rectangular CRT. Triggering controls include alternate

channel triggering, variable trigger hold-off, TV sync separators and line triggering. An internal graticule, auto-focus and scale illumination are also standard.

Circle (83) on Reply Card

VCR repair kit, cassettes

Jensen Tools has introduced the Telvac VCR service/repair kit and a line of VCR test cassettes. The repair kit



contains a selection of specialty tools used to service VCRs, including lubricants, alignment tools, fine-adjustment metric tools and cleaning equipment. Three test cassettes are also available. The tape path-view cassette provides a front-view window for observing the tape in operation. The torque meter-play and fast-forward/rewind cassettes measure torque levels.

Circle (84) on Reply Card

Modular workstation

The Rack modular workstation system from the Assembly Systems Group allows the user to position tools and equipment where they may be reached more efficiently. Modular design and in-

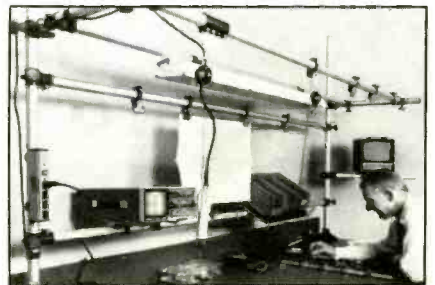

finite adjustability make the system easy to adapt to individual needs. The system will support up to 200 pounds on the vertical holding surface. Bench models, free-standing models and add-on accessories are available.

Circle (85) on Reply Card

CALL TOLL FREE

Include work address and phone number for Free Catalog.

800-824-2873

DIGITAL MULTIMETERS

BECKMAN

Beckman Industrial!

- All 300, HD, and Circuitmate series
- All accessories in stock

MODEL	PRICE
HD100	\$169
HD110	\$199
HD130	\$259
HD140	\$279
300	\$120
310	\$145
310B	\$155
320	\$179
320B	\$189
330	\$219
350	\$229
360	\$289
4410	\$239

FLUKE

- Autorange Analog display
- Touchhold function
- 0.3% accuracy Heavy duty

MODEL	PRICE	MODEL	PRICE
21	\$ 99	75	\$119
23	\$149	77	\$149
25	\$199	8010A	\$299
27	\$259	8012A	\$359
37	\$249	8020B	\$219
52	\$169	8024B	\$259
73	\$ 79	8050A	\$399

Hand held DMM

FLUKE 23YEL

SALE \$120

LIST \$145

WAYNE KERR

MODEL	PRICE
4210	\$2650
4225	\$1950

SCOPES

HITACHI

Hitachi

Denshi America, Ltd.

- All 20 models in stock
- 2-3 year warranties
- 20-100 MHz

MODEL	PRICE
V209	\$ 895
V222	\$ 530
V422	\$ 740
V425	\$ 796
V660	\$ 985
V665	\$1255
V680	\$1341
V1060	\$1345
V1065	\$1615
V1100A	\$2116

HITACHI V-509

Portable Dual Trace Scope

SALE \$1199

LIST \$1445

IWATSU



- All 14 models in stock
- 2-3 year warranties
- 20-250 MHz

MODEL	PRICE
5702	\$ 535
5705	\$ 899
5706	\$ 749
5710	\$1245
5711	\$1695
5712	\$2999

POWER SOURCES

POWER DESIGNS

- Low and high voltage power sources
- 1-5 year warranties

MODEL	PRICE
TP340	\$ 805
TP343A	\$ 855
TW347D	\$ 855
TW5005D	\$ 625
TW6050D	\$1075
2K20A	\$1095
2020B	\$ 850
4050D	\$ 805
5020	\$ 925
6010D	\$ 495
6150	\$ 775

USED TEST EQUIPMENT, TOO!—OVER 3,000 MODELS AVAILABLE AT HUGE DISCOUNTS WITH WARRANTIES!

■ Quantity Discounts Available ■ Dealers Welcome ■ Freight and Tax Extra ■ Immediate Availability of Equipment

US United States Instrument Rentals, Inc.

A U.S. Leasing Company
2988 Campus Drive
San Mateo, CA 94403

Circle (33) on Reply Card

Extender board

BICC-VERO has introduced an extender board that facilitates fault-finding on expansion boards for IBM PC/XT/AT and compatible computers. The board is designed to plug into the expansion slots on the motherboard and bus the expansion lines to the equivalent socket. The board allows bus lines to be interrupted for system proving. By breaking tracks at marked points, the user can insert jumper links to open-circuit or close bus lines.

Circle (86) on Reply Card

Digital multimeters

The 6000 series DMMs from **Goldstar Precision Company, Ltd.** feature audible continuity, data-hold memory, a 10A resettable fuse, a low-battery indicator, overload protection and an ac/dc indicator. The DM-6133 is a manual, dial-type meter. Models DM-6135, DM-6235 and DM-6335 are auto-ranging.

Circle (87) on Reply Card

Soldering iron

The Antex model C/3U miniature soldering iron from **M.M. Newman** is equipped with a 0.012-inch tapered needle tip, a 6-foot cord and a 3-prong grounded plug. The iron weighs 0.75 ounce and heats up to 725°F in 45 seconds. More than 40 styles of slide-on tips, which have no threads or set screws, can be used with the iron.

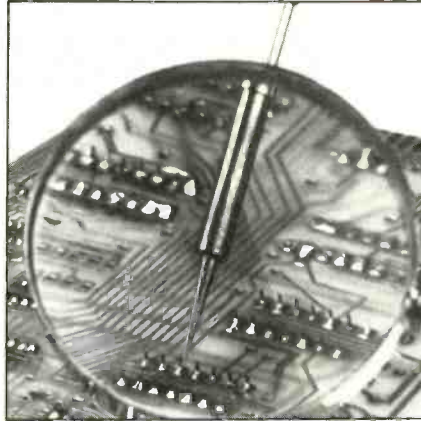

The iron weighs 0.75 ounce and heats up to 725°F in 45 seconds. More than 40 styles of slide-on tips, which have no threads or set screws, can be used with the iron.

Circle (88) on Reply Card

Soldering/desoldering tweezers

Wybar Electronics has introduced the model SD-1 surface-mount component desoldering and soldering tweezers. The tweezers allow closely spaced SMT devices to be desoldered, removed and replaced with one hand. The separate power unit allows adjustable element temperatures between 200°F and 800°F. The device comes with two styles of desoldering elements. The wire-style elements may be formed with pliers to an exact configuration. The special small elements are preformed to handle components as small as 0.12-inch wide.

Circle (89) on Reply Card

SMT repair tools

A series of eight precision tools with stainless steel tips are available from **Desco Industries** for use in circuit board and SMT repair and rework. The tools have hex-shaped plastic handles for easier grip. Six end styles are available.

Circle (90) on Reply Card

ES&T INC.

Technicians,
Get Serious
About Your
Profession



Being a certified electronics technician lets people know that you are a professional in your field. It tells them that you are serious about your work and can perform up to CET standards.

Now you can order the "Study Guide for the Associate-Level CET Test" from the International Society of Certified Electronics Technicians. It includes material covering the most often missed questions on the Associate CET exam. 8 1/2" x 11", paperback, 60 pages.

For More Information Contact:

IS CET, 2708 W. Berry, Fort Worth, TX 76109; (817) 921-9101

NAME _____

ADDRESS _____

CITY _____ STATE _____

ZIP _____

_____ copies @ \$5 (+ \$1 postage.)

_____ send material about IS CET and becoming certified.

INTRODUCING THE AR-100 MAXI-PROBE™

The World's First Pen-Style DMM
with Built-In 10MHz Logic Probe

INNOVATION, NOT IMITATION

The AR-100 Maxi-Probe. Unheard of features and performance in one small package. Volts, Ohms, Audible continuity, Data Hold. Then add a full-function, TTL/CMOS logic probe. Screw on accessory tips. Diode Test. Test Leads. And a storage case.

Result: All the functions you need for both analog and digital testing in one small package, at one low price.

So visit your local ARI distributor and take hold of the future, today. The AR-100 Maxi-Probe. All others pale by comparison.

Measure:
•Volts •Ohms •Diodes
•Audible Continuity
Add:
TTL & CMOS Logic To 10MHz!
Features:
•Screw-On Accessory Tips
•Data Hold



AMERICAN RELIANCE INC.
VALUE BEYOND MEASURE

9241E, VALLEY BLVD. ROSEMEAD, CA 91770
(800)654-9838

ARI manufactures a complete line of electronic test equipment, including EPROM, EEPROM, and PLD programmers, IC testers, Cable testers, DPMs, DMMs, and Logic testing devices. Call or write today for your free Brochure.

Circle (34) on Reply Card

What do you know about electronics? --

Thermistor bridges

By Sam Wilson, CET

The resistance of a thermistor depends upon its ambient (surrounding) temperature. Most thermistors have a negative temperature coefficient, so an increase in temperature causes a decrease in resistance. However, there are thermistors with positive temperature coefficients—that is, their resistance goes up when the temperature goes up.

One application of thermistors is in temperature measurement or temperature sensing. The thermistor is placed at a point where the temperature is to be sensed or measured. The surrounding temperature sets its resistance, and that resistance affects the circuit in some way.

Wilson is the electronics theory consultant for ES&T.

The overall effect is to display or use the resistance of the thermistor to determine the temperature at some point. The point of interest can be in a remote position.

Figure 3 shows a simple circuit that could be used to sense temperature. The meter is calibrated when the thermistor is cold. Then, the thermistor (still connected) is put in the place where the temperature is to be sensed.

Assume that the meter has been properly calibrated to display the temperature. As the temperature goes up, the resistance goes down. More current flows and the meter moves up-scale to display the temperature.

The circuit in Figure 1 would work, but not very well. The current from the

battery flows through the thermistor and heats it. That must be taken into consideration when the meter is calibrated. Also, as the battery ages, it is not able to deliver as much current. The circuit, therefore, must be frequently calibrated.

The bridge circuit in Figure 2 is *balanced* when $R_1/R_3 = R_2/R_4$. When it is balanced, there is no current through the meter.

The current will stay in balance regardless of any change in the battery voltage or circuit current. However, a change in one of the resistance values—say R_4 —will unbalance the bridge and current will flow through the meter.

You could put a thermistor in place of R_4 . Then, if the circuit is properly balanced, the meter could be calibrated

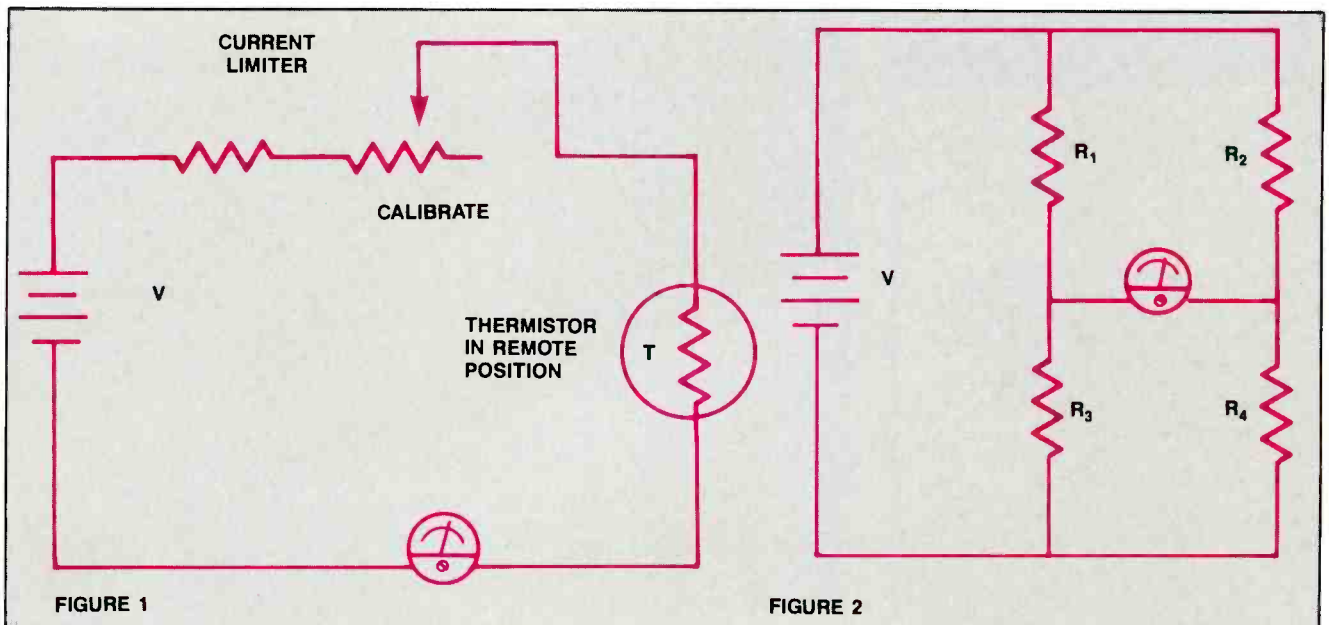
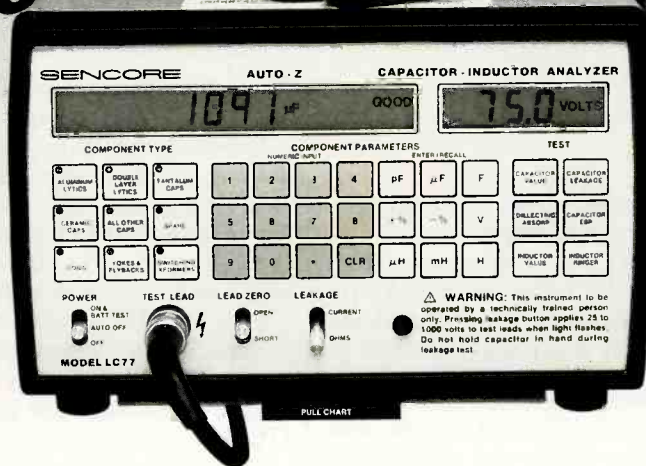

Figure 1. This simple circuit could be used to sense temperature. However, the current from the battery flows through the thermistor, heating it, and the age of the battery would determine the amount of current flow.

Figure 2. The bridge current in this figure is balanced when $R_1/R_3 = R_2/R_4$, so no current flows through the meter. A change in one of the resistance values would again unbalance the meter, however. Using just one thermistor in place of a resistor would work, but a change in room temperature would again unbalance the bridge.

Discover How The World's Only
**100% Automatic, Dynamic, & Portable
 LC Analyzer Gives You Total Confidence
 In Your Cap/Coil Testing . . .
 Call 1-800-843-3338 Today!**

New



**LC77 AUTO-Z™
 Automatic Capacitor and Inductor Analyzer
 Double Patented \$1,895**

IEEE - 488

The first cap/coil analyzer guaranteed to reliably test anywhere, without calculations, look-up tables, or error — 100% automatically so you're confident of your accuracy.

Do you want to eliminate doubt from your cap/coil testing? The LC77 AUTO-Z tests all key parameters with results anyone can understand. Automatic good/bad results eliminate the guesswork for error-free analysis. Touch-sensitive keypad and one-two-three setup makes your AUTO-Z the easiest and most accurate LC analyzer on the market.

Are you frustrated trying to test the new high-tech caps/coils used in modern electronics? Only the LC77 AUTO-Z allows you to test them all. Test capacitors from 1 pf to 20 farads, with leakage tests to 1000 V and ESR to 2000 ohms for locating failures other testers miss. Inductor value from 1 uh to 20 H. Patented ringing test for dependable, error-free coil testing every time.

Do you need the freedom of a battery-operated portable LC meter? The LC77 AUTO-Z is 100% battery portable for use in the field or factory. The full power and accuracy of the LC77 AUTO-Z is packed into a light-weight, portable package. The LC77 AUTO-Z puts the complicated electronics on the inside for ease of operation on the outside.

Do you want maximum efficiency with a bus compatible LC testing system? The LC77 AUTO-Z is IEEE 488 compatible for automated cap/coil analysis for test collection, incoming inspection, and quality assurance tests.

Are you satisfied that you can meet all the challenges new technology brings. Call Sencore Free 1-800-843-3338 today and tell your Area Sales Engineer you want to "buy before you buy" with Sencore's exclusive 10 Day Self Demo.

LC77 AUTO-Z is a trademark of Sencore, Inc.

WATS Free 1-800-843-3338 In Canada WATS Free 1-800-851-8866

SENCORE

Means Success In Electronic Servicing

3200 Sencore Drive, Sioux Falls, South Dakota 57107

Call Collect 605-339-0100 In SD & AK

Circle (35) on Reply Card

April 1988 *Electronic Servicing & Technology* 53

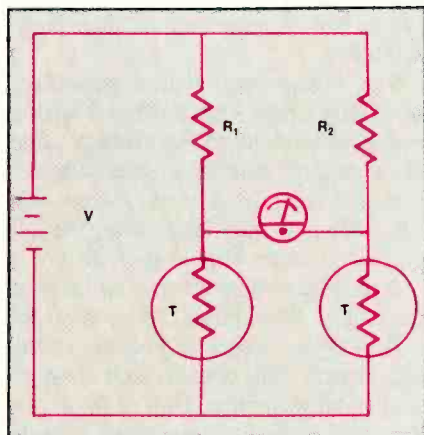

Figure 3. Thermistors in place of R_3 and R_4 sense temperature but shouldn't be affected by voltage or current changes or room-temperature changes.

to read a change in thermistor resistance

letter is printed here.

"The calculator method of the deci-

mal-to-hex conversion on page 57 of the January issue is a little bit confusing. I use the following method:

"Divide 745 by 16 on the calculator, then multiply the fractional remainder by 16 to get the whole-number remainder. List the remainders from left to right.

$745/16=46.5625$; $0.5625 \times 16=9$
 $46/16=2.875$; $0.875 \times 16=E$
 $2/16=0.125$; $0.125 \times 16=2$

"Therefore, decimal 745 equals hex 2E9."

A comment about home-brew equipment

I got a very interesting comment from Al Jagnow of North Liberty, IA. He does not feel that the logic pulser in the January issue was useful. He says:

"I estimate the parts cost at about \$20, if you can't scrounge anything from your junk box. Add in the cost of laying out and etching a circuit board and you're looking at \$30 if your time isn't worth anything. Our shop minimum labor rate is \$35 per hour. Add in four hours labor and the probe has cost \$170."

According to Mr. Jagnow, home brew is wonderful only if:

1. The equipment is not available from some other source.
2. Performance or quality is better than commercially available equipment.
3. There is a substantial savings in building it yourself.
4. You need something in a hurry and can't wait to purchase it.
5. You are building equipment as a hobby—for enjoyment.

I'm not sure I agree. When I do something nice for myself—like build myself a piece of test equipment—I just don't have the nerve to charge myself labor. After all, a gift of love should not have a price tag. I wouldn't build it during working hours, so I'd fall into category number 5.

You have to keep in mind that there are hobbyists, students, retired people and others who like this kind of project. However, I think some of Mr. Jagnow's points are well taken. I don't propose to turn the article into a do-it-yourself series. However, if you have a contribution, I'll certainly give it space.

What is a neutral isolator?

Rapid Roy Delange of Circle Pines, MN, sent a copy of an article that ran

in *The Farmer's Digest*. This article claims that milk production was increased by 700 pounds per cow when "neutral isolators" were installed. The title of the article was "Neutral isolators prevent stray voltage."

Mr. Delange wants me to explain that. Being city bred, I'm not sure how the cow works. I'm going to have to turn this one over to the readers. Anyone want to field this one?

"Test Your Electronics Knowledge" corrections

Did you ever try to fix something that got worse every time you did anything to it? The in-situ tester for transistors has turned out to be a nightmare for me. (See "Test Your Electronics Knowledge" in the September 1987 issue.)

First, I tried to make the circuit more professional by "straightening out the lines." The result was a dead short across the battery—and many letters. (The letters were the good part.)

Next, I decided to get rid of the problem by printing the original circuit as it was given to me. That *had* to be safe. The trouble with that was that the person who sent it to me had made a copy from his original. With that version, it was not possible to check a PNP transistor. As soon as that version came out, the letters came again.

Let me say this: I sincerely appreciate the letters and final solutions that were sent. I picked the correct and final version of the switch (see Figure 4) from Raymond McCoy's note. There were

many other correct solutions, but this one had the earliest postmark.

Ralph Johnson in Lansing, KS, correctly pointed out an error in the ninth question in the January 1988 quiz. He noticed that R_2 is the source resistor of the JFET. In my discussion of the answer, I carelessly called it R_1 . The answer (choice A) was correct as given.

I received a lot of mail on the quiz in the December 1987 issue. In Figure A (question number 2) the real trouble is in the drawing of the transformer. The voltmeter across the secondary should be a dc meter, not an ac meter as shown. Regardless of what the secondary voltage is, the dc meter should show zero deflection.

The voltage across the secondary *should* be a pure sine wave. An analog meter will deflect to the average value of the voltage being measured when it is on the dc scale. Because the average value of a sine wave is zero over the full cycle, the meter should indicate 0V.

If there are shorted turns on half the secondary, the core of the transformer will likely be saturated because of the high current. The overall result is a non-sinusoidal waveform. Half of the waveform will be in the shape of a half-cycle of pure sine wave; the other half will be non-sinusoidal shorted because of the saturation. This test works best when a full-wave rectifier and load resistor (no filter) is connected.

When the waveform is no longer a pure sine wave, there will be a deflection of the dc meter away from zero.

ES&T

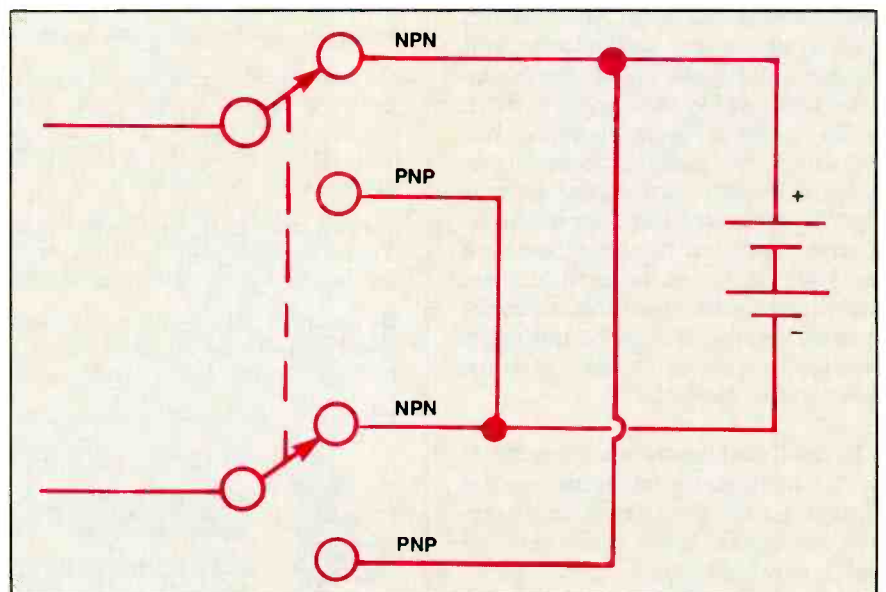

Figure 4. Removing the dead short across the batteries allows this in-situ transistor to work.

Quiz answers

Questions are on page 20.

1. B—dc. This test is described in this issue's "What Do you Know About Electronics?"

2. Yes—If you know the diodes are identical, the 1/2-waves of a complete cycle should have the same amplitude.

3. No—The wire sizes are usually different.

4. A—Modulation of two signals cannot take place in a truly linear amplifier.

5. A pure sine wave has no harmonics.

6. A straight line. If the line isn't straight you have linear distortion. If you get an ellipse, you have phase shift distortion.

7. C—Neither the ohmmeter nor the bridge should be used because they both produce current in the thermistor. That heats the thermistor and changes its resistance.

8. An oscillator.

9. B—The chop mode. The chop mode kicks back and forth between the two waves so rapidly that you think both waveforms are on at the same time. At low frequencies, you see only a small part of the waveforms with each kick.

10. Use a dc voltmeter across the output. Adjust for 0V.

The SC61 Waveform Analyzer™

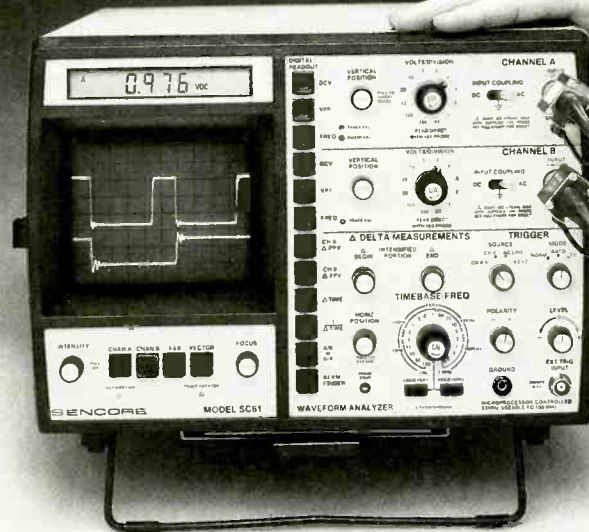

\$3,295 Patented

Here's what we say:

With just one probe hookup you can confidently analyze any waveform to 100 MHz, 10 times faster, 10 times more accurately, absolutely error-free — guaranteed or your money back.

Here's what our customers say:

"The SC61 gives the most information with a minimum of probe-swapping and knob turning."

Patrick Lyman
Biomedical Electronics
Los Angeles, CA

"In my use of the SC61 Waveform Analyzer, it has reduced the amount of time in half in fixing communications equipment."

Jeff Williams
Computer/Communications Repair
Madison, TN

"We have a small shop and need all the short cuts, time saving equipment we can get. Sencore passes with flying colors. Every tech should try their techniques with the SC61 Waveform Analyzer. Does what it should and more."

Bill Humble, Jr.
VCR, Audio and CB Repairs
Yulee, FL

**Discover What The SC61 Waveform Analyzer
Can Do For You! Call Today 1-800-843-3338.**

In Canada Call 1-800-851-8866.

100% American Made

SENCORE

3200 Sencore Drive, Sioux Falls, SD 57107 605-339-0100 In SD Only

Circle (36) on Reply Card

April 1988 *Electronic Servicing & Technology* 55

CD digital error correction

By Kirk Vistain

Last time, we adjourned with "EFM" ringing in our ears. Actually, if the collimated laser beam were narrow enough, EFM wouldn't be necessary. If media, servos and mass-produced products were good enough, we wouldn't need to spend this column talking about error correction. But, as Harry Callahan said, "A man's got to know his limitations."

The people who developed the CD system were well aware of the shortcomings, so they designed parity (correction) schemes that make all but the worst defects virtually inaudible. It's important to note that the processing discussed here occurs *before* 8-to-14 modulation in the recording process and *after* 14-to-8 demodulation during playback.

Why error correction?

One track on a compact disc is 1.6 microns wide. Just one errant human hair could obscure 40 tracks. A piece of dust that would barely cause a crackle on a phonograph record might obliterate tens of digital words on a CD. In the analog world, small changes produce small results. If head azimuth is a little off, so is the high end. Not quite enough bias current in an amp and you might hear a little crossover distortion. But with digital information, there is no margin for error. Changing just one bit of a word may make the audio reproduction unlistenable—hence the need for error correction.

Cross interleave Reed-Solomon code (CIRC) is the antidote for our trouble. Combining a cyclical redundancy check code (CRCC) and interleaving of data corrects most dropout errors.

Here's how it works: During recording, digital data is divided into blocks, similar to that in Figure 1. The words in each column and row are added together. A variable value called a *parity*

Recorded data					
02	06	05	+	07	= 20
04	08	06	+	02	= 20
03	05	07	+	05	= 20
+	+	+			
11	01	02	—	Parity	CRCC
20	20	20	-----		
Reproduced data					
02	06	03	+	07	= 18
04	08	06	+	02	= 20
03	05	07	+	05	= 20
+	+	+			
11	01	02	—	Parity	CRCC
20	20	18	-----		

Figure 1. Here a dropout has caused the reproduced CRCC to differ from the recorded one in a single row and column. Their intersection is row 1, column 3. The value is 03 instead of 05. The error correction software knows it must increase this by 02 to recover the correct information.

(*P*) word is then added to make the total of each row and column equal the CRCC number, which is the same for each. This information is then added to the program (music) data and recorded.

During playback, the CD player constantly compares the recorded CRCC value against its own calculations of the program data. Even with the best disc, a dropout will occur, on average, at least once per second. By noting the row and column in which the calculated CRCC differs from the recorded value, the processing circuitry can pinpoint the erroneous word. Reconstruction is a simple matter of changing the word so the row and column CRCC sums equal the recorded value.

On an actual CD, the blocks of data are much larger than our example, adding up to 12 16-bit words (192 bits) plus 64 bits of redundant (CRCC) data. Error correction accounts for 33% of this information. To further lessen the

chances of unrecoverable errors, the audio and CRCC data alternate within a channel frame. (I'll discuss the exact layout next month.) This creates a block of audio, followed by a block of CRCC, followed by another block of audio, then CRCC again.

Burst error

This strategy works well with errors encompassing only a bit or two, but what if a large block of data is wiped out, parity, CRCC and all? This is a *burst error*. The loss of even one row or column would make the data unrecoverable. Interleaving is the answer.

Figure 2 diagrams the effect of burst error. The data is scattered throughout a block according to a complex algorithm, compliments of Reed-Solomon. At this point, the sequence of recorded words no longer matches the natural order of the recorded event. If a scratch or pinhole wipes out a large section of the disc, it is likely that enough information can be recovered from undamaged portions of the track to reconstruct the original data.

All this is very clever, but a really large defect can make even CIRC ineffective. When the processing circuitry encounters one of these unrecoverable errors in the de-interleaved data, it interpolates the values by simply taking the first good data ahead of and behind the error, then plotting a smooth curve between them. This usually works, but it assumes a smooth transition from one level to another, which is not always the case with real music. So, occasionally, this type of correction is audible.

What if all of this sophisticated number crunching still can't cope with the loss of data? Click, pop, crackle, skip. Just like crotchety old analog records. Practically speaking, a good CD player can track defects of up to 900+ microns in the information layer.

The digital processor IC in most CD players has a window to the operation

Vistain is the audio consultant for ES&T.

Now test and restore every CRT on the market . . . without ever buying another adaptor socket or coming up embarrassingly short in front of your customer . . . or your money back



Data in "natural" sequence				
01	02	03	04	05
<u>06</u>	<u>07</u>	<u>08</u>	<u>09</u>	<u>10</u>
11	12	13	14	15
16				
Interleaved data				
06	09	01	05	15
<u>02</u>	<u>13</u>	<u>07</u>	<u>04</u>	<u>16</u>
14	10	08	03	12
11				
De-interleaved data				
01	<u>02</u>	03	<u>04</u>	05
06	<u>07</u>	08	<u>09</u>	10
11	12	<u>13</u>	14	15
<u>16</u>				

Figure 2. Underlined data words indicate the scope of a possible burst error. It obliterates several consecutive words recorded in natural sequence, making this data unrecoverable. The same level of damage to interleaved data is spread out after de-interleaving, allowing software to correct several smaller problems instead of a single large one.

of the error-correction circuitry. The terminology and exact implementation varies, but usually you'll find at least a pin that flags unrecoverable errors (ones that can't be corrected by CIRC). Some chips have pins that indicate at which particular CRCC block the problem occurred.

I've tried monitoring these with an eye to using the output for fine-tuning the servos and PLL. Forget it. The number of CRCC and unrecoverable errors tell you a lot about the condition of the disk, but little about the condition of the disk player. Varying tracking, focus and PLL adjustments produces little or no change in the error rate, until they are so far out of range that the player shuts down. If someone else has had better luck with this, please write in and share your experience with us.

ES&T

with the new improved CR70 "BEAM BUILDER"™
Universal CRT Tester and Restorer
\$1,295

Have you ever?

Thrown away a good TV CRT, data display CRT, or scope CRT that could have been used for another two or three years because you had no way to test or restore it?

Lost valuable customers because you advised them that they needed a new CRT when another technician came along and restored the CRT for them?

Lost the profitable extra \$35 or more that you could have gotten for restoring a CRT while on the job and locked in the profitable CRT sale later?

Avoided handling profitable trade-ins or rentals because you were afraid you'd have to replace the picture tube when you could have restored it?

Had a real need to test a CRT on the job, but didn't have the right adaptor socket or setup information in your setup book?

If any of these things have happened to you, **CALL TODAY, WATS FREE, 1-800-843-3338**

WATS Free 1-800-843-3338 In Canada WATS Free 1-800-851-8866



SENCORE

Means Success In Electronic Servicing

3200 Sencore Drive, Sioux Falls, South Dakota 57107

Call Collect 605-339-0100 in SD

Circle (37) on Reply Card

The ripple counter

By Christopher H. Fenton

This is the last in a 2-part series on flip-flops. Part I discussed the different types of flip-flops and introduced the ripple counter, which will be discussed in more detail in Part II.

A ripple counter is created by a series of flip-flops cascaded to successively divide the output of a digital circuit by powers of two. It is called a ripple counter because each successive output, clocked by the output of the previous stage, "ripples" from stage to stage.

Although Type 74 flip-flops can be infinitely configured to give the desired number of steps in a ripple counter, in applications in which more than four stages are required, it is usually more cost-effective to use a special-purpose MSI ripple-carry binary counter/divider, such as Texas Instrument's Type 4024.

The MSI ripple-carry counter/divider

Designed as a 7-stage ripple counter, the Type 4024 has seven outputs (see Figure 1) that are externally accessible, and the IC provides a maximum division ratio of 2^7 th power. The TI Type 4040 (Figure 2), on the other hand, is a 12-stage chip that provides a division ratio of 2^{12} th power and complete ac-

Fenton is the circuit fabrication consultant for ES&T.

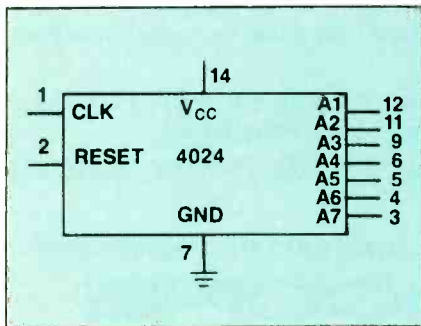

Figure 1. The pinout of the 4024, a 7-stage chip, shows seven outputs that are externally accessible. The maximum division ratio is 2^7 th power.

cess to all 12 stages of output. The TI Type 4060 (Figure 3) is a 14-stage device. All of its outputs, except 1, 2, 3 and 11, are externally accessible, providing a division ratio of 16,384 or 2^{14} th power. The Type 4060 incorporates a built-in oscillator circuit that allows the frequency of oscillation to be set by a crystal or RC network.

Each of these devices has a Schmitt-triggered input, which is engaged to the negative transition of each input pulse. By applying a high level to the reset line, a chip's counter can be set back to zero.

The more stages, the more glitches

However, one of the problems with ripple counters is that glitches are produced by the delay created by cascading several levels of asynchronous devices. In a 2-stage ripple counter, there are

four possible output states in which glitches may occur: A1, A2 high; A1 high, A2 low; A1 low, A2 high; A1, A2 low. A clock pulse can only be received when A1 and A2 are low. When the first clock pulse is input, A1 goes high. The second clock pulse causes A2 to go high and A1 to go low. The third clock pulse causes both the outputs to go high. On the fourth pulse, the outputs return to their original state.

Because the ripple counter is an asynchronous device, the propagation delay between the two flip-flops may cause glitches or variations in any of the possible decoded outputs. Glitches are possible at any stage of the output. As a general rule, the greater the number of stages, the greater the glitch problem. One of the possible solutions is to use a synchronous device such as a Johnson counter.

The Johnson counter

A Johnson counter (such as the TI Type 4017) is a synchronous divide-by-10 counter that clocks all the flip-flops on and off at the same time. Based on the programmable nature of a JK flip-flop, the Johnson counter is able to act as a standard set/reset latch or as a binary divider.

In a Johnson counter, all of the flip-flops are clocked parallel. They also are cross-coupled so that the response of one stage to the clock is determined by the state of the other stages.

Data is latched into the first flip-flop at the start of the cycle while A1 and A2 are both low, instructing it to change state. When the first clock pulse arrives, the device changes state and A2 goes low.

New program information is fed into the flip-flops when the clock goes low again. The first flip-flop in the series is instructed to change state. The second flip-flop is instructed to set A2 high. On the positive transition of the second

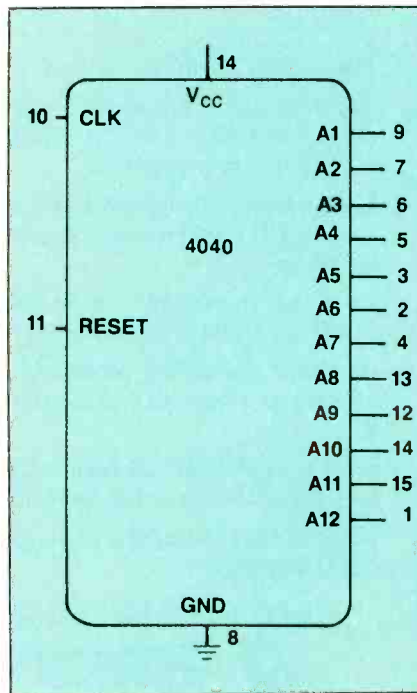

Figure 2. The 4040 ripple counter is a 12-stage chip that provides a division ratio of 2^{12} th power. All 12 stages of output are accessible.

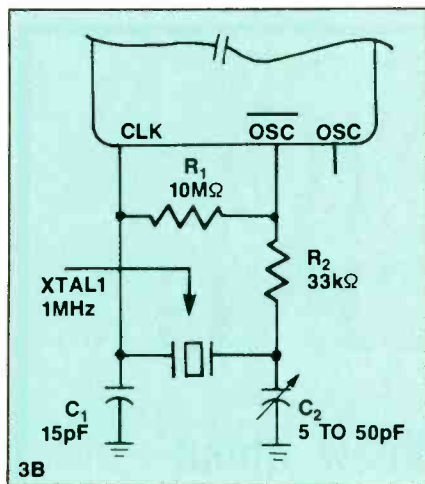
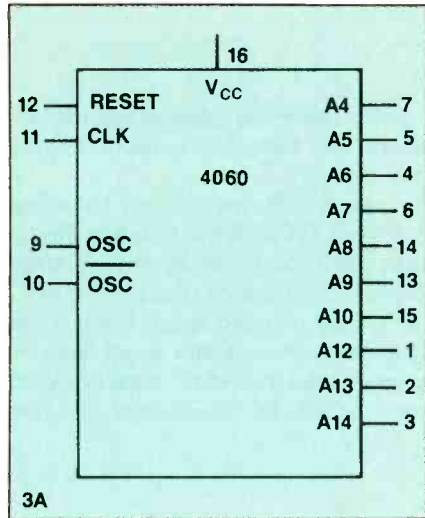
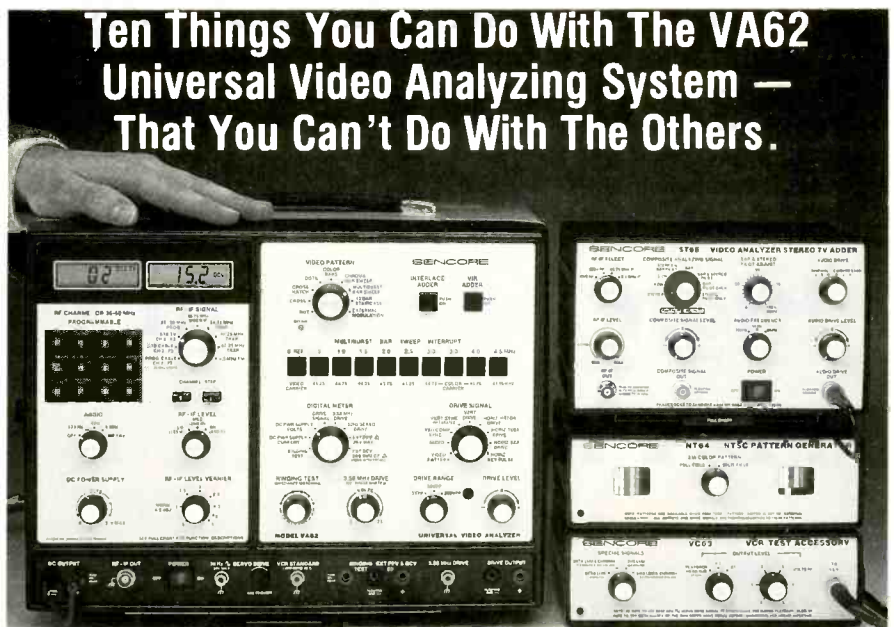

Figure 3. With the 4060, a 14-stage device, all the outputs but 1, 2, 3 and 11 are externally accessible, providing a division ratio of 12^{14} th power (Figure 3A). A built-in oscillator circuit (Figure 3B) allows the frequency of oscillation to be set by a crystal or RC network.

clock pulse, the instruction is executed. This causes A2 to go high and A1 to go low. When the clock is low again, new program information is fed into each flip-flop from the output of the succeeding flip-flop. The sequence repeats itself infinitely.

ES&T



\$3,495 Patented

1. Quickly locate defective circuits by injecting signals without disconnecting components.
2. Replace video heads with confidence; a simple good/bad head test removes all doubt.
3. Align IF traps simply by just the pattern on the CRT — have the picture "looking like it did when they bought it."
4. Quickly align VCRs with special video patterns, or NTSC color bars. Meets all manufacturers' warranty requirements.
5. Performance test and troubleshoot any MTS stereo TV or VCR system, so you can cash in on new technology.
6. Confidently test deflection yokes, IHVTs, and flyback transformers, in-or out-of-circuit, before you replace them.
7. Add on phase-locked accessories into your video analyzing system to increase service potential as technology changes.
8. Performance test and troubleshoot digital/analog RGB video monitors, so you can test all of today's video systems.
9. Conquer tricky servo circuits in VCRs by injecting a reference 30 Hz servo pulse.
10. Cut your video servicing time in half . . . or your money back.

Discover what the Universal Video Analyzing System can do for you! Call Today 1-800-843-3338.

In Canada Call 1-800-851-8866.

100% American Made

SENCORE

3200 Sencore Drive, Sioux Falls, SD 57107 605-339-0100 In SD Only

Circle (38) on Reply Card

April 1988 *Electronic Servicing & Technology* 59

High fidelity in VCRs -- Part II

By Conrad Persson

This is the second part of a 3-part series on high-fidelity audio circuits used in VCRs. Part I described how the audio and video signals are recorded. Part III will discuss the playback circuits. (Adapted from GE's "VCRs and Video Cameras, 1985 Line.")

High-fidelity audio is recorded on videotape by audio heads mounted on the video-head cylinder. The audio heads are positioned 120° apart from the adjacent video head with

Persson is editor of **ES&T**.

an azimuth angle of $\pm 30^\circ$. The video signal is recorded on top of the audio signal, but to a more shallow depth. (Figure 1 shows the tape track pattern.)

A simplified block diagram of the high-fidelity recording circuit (left channel) of a GE 1VCR5018 is shown in Figure 2. Recording level input can be controlled by an AGC stage or by a manual, front-panel, record-level control. The AGC stage will maintain an overall constant signal level, while the manual adjustment allows the operator to set what he considers to be the optimum level from observation of record level meters. Automatic or manual record-level selection

SPECIAL REPORT
SPECIAL REPORT
SPECIAL REPORT
SPECIAL REPORT
SPECIAL REPORT
SPECIAL REPORT
SPECIAL REPORT
SPECIAL REPORT
SPECIAL REPORT
SPECIAL REPORT
SPECIAL REPORT
SPECIAL REPORT
SPECIAL REPORT
SPECIAL REPORT
SPECIAL REPORT

AUDIO SERVICING

All you need to know about servicing audio equipment is in this exclusive report coming in May in:

ELECTRONIC
Servicing & Technology

Figure 1. The tape track-pattern of the VHS high-fidelity system shows how the FM audio track addition is recorded over the video signal.

A benefit of dynamic range compression is that it limits the amount of noise recorded on the tape.

is made by a front-panel switch that activates switching circuitry inside IC4207.

Getting the best sound

Signal processing (to emphasize high-frequency, low-level portions of the signal) and noise reduction are performed next in IC4205. During the record mode, the audio signal is compressed by the noise-reduction stage to half its

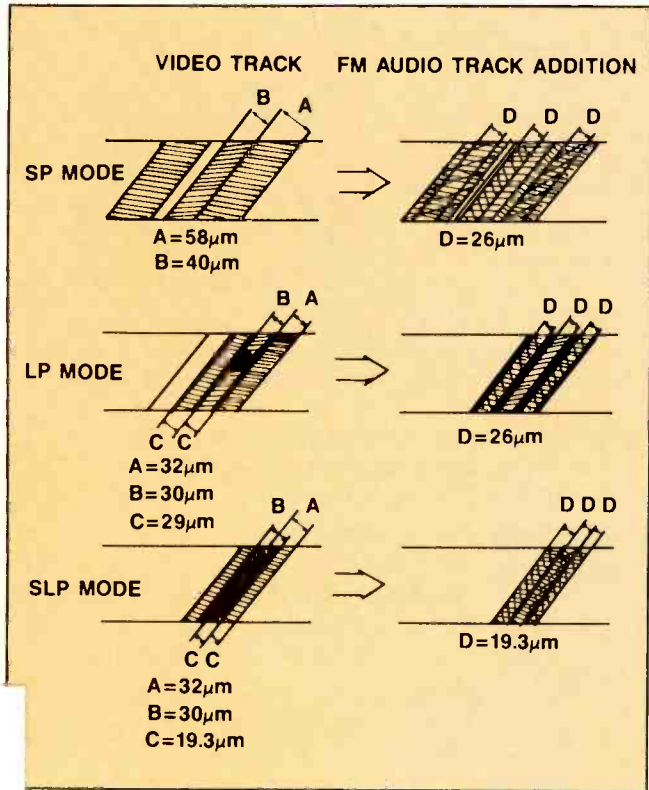

**ZED
S**

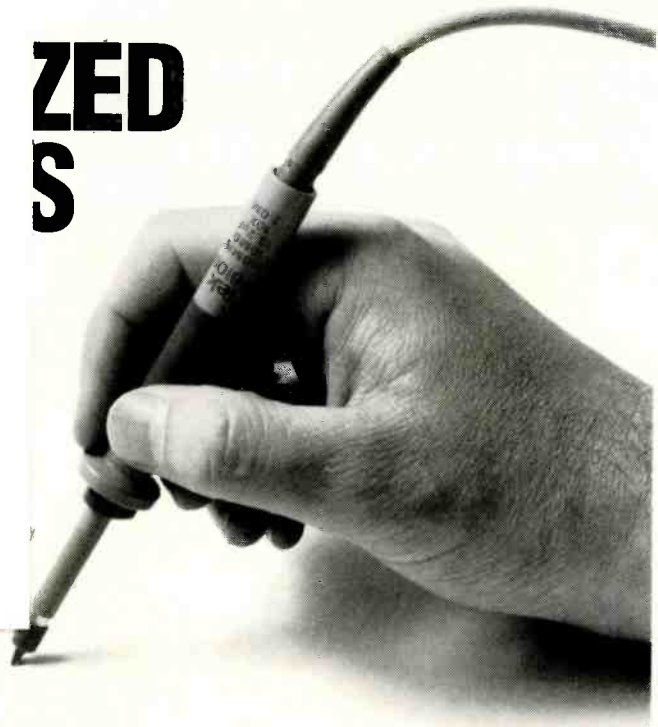

To order call toll free **1-800-426-2200**

VISA and MasterCharge accepted.

Tektronix
COMMITTED TO EXCELLENCE

I WAS HOPING FOR A DAY OFF, BUT WITH MCM ELECTRONICS SUPPLYING THE PARTS...

Until I started ordering my parts and components from MCM's extensive catalog, I used to have lots of days off because I just couldn't get the items I needed...when I needed them.

Now, that's all changed. Whenever I order a part from MCM, chances are, it's in stock and shipped to me immediately. If I need a hard-to-find part, they've got that, too! But I am real thankful that MCM has such great prices and flexible payment terms that I can now make my customers a better deal...and myself a better profit at the same time!

If you are looking for a dependable electronics parts and components supplier, the MCM ELECTRONICS Catalog is for you!



For your **FREE** copy, call **TOLL-FREE!**
1-800-543-4330
In Ohio, call **1-800-762-4315**
In Alaska or Hawaii, call **1-800-858-1849**



MCM ELECTRONICS
858 E. CONGRESS PARK DR.
CENTERVILLE, OH 45459-4072
A PREMIER Company

SOURCE NO. ES-32

Circle (40) on Reply Card

BOARD REPAIR DEPOT 1 YEAR GUARANTEE!

BOARD REPAIR:

- Exceptional Quality & Reliability
- * Advance Exchanges Available
- * IBM PC, XT, AT
- AT&T 6300
- * COMPAQ
- EPSON
- TI

TESTING:

- 100% Functional test
- 12 hour Burn-in @ 115°F
- Outgoing final test and inspection

1-800-BOARDFX

D. S. Walker & Associates, Inc.

11210 Steeplecrest Suite #300 Houston, Texas 77065 (713) 890-2257

Circle (48) on Reply Card

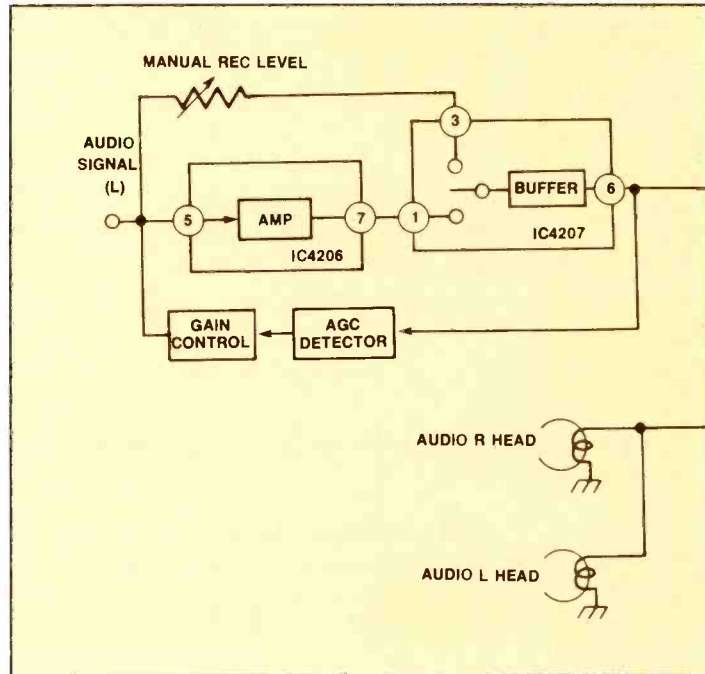

Figure 2. This simplified block diagram shows the hi-fi recording circuit (left channel).

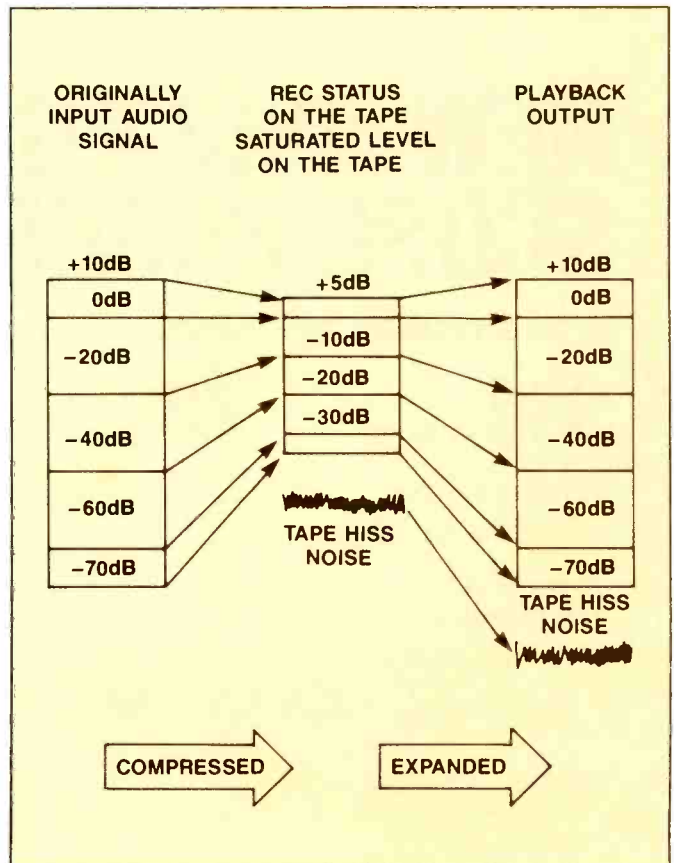

Figure 3. During the record mode, the system uses dynamic range compression to limit noise and prevent tape saturation. The dynamic range is expanded back to its original characteristics during playback.

NEW

"FOR ZENITH T.V. SERVICERS"

For Zenith models V, Z, A, B and C send us all modules, leaving tuner control, picture tube, yoke in set, and we will repair your modules with full warranty for only \$39.95 —that's right 39.95* ... Look:

All you need to do is this:

1. Tell us the problem.
2. Send us all modules (except tuner control, picture tube and yoke.)
3. Do not remove chips and transistors from their position.
4. If you wish mark chips, and modules.

We will:

1. Repair your modules.
2. Provide full warranty for 6 months, including flyback and chips.
3. Return your modules with no service charge if found in proper working order.
4. Provide tips for reinstallation of modules.
5. Work done and supervised by Certified Electronic Technician.

WHAT ARE THE BENEFITS TO YOU?

- No inventory
 - No guess work
 - Fast turn around
 - Lower cost per service
- For free technical assistance call: 1-800-759-6767
9-6 Eastern Standard Time
* Free Return Shipping
* IC'S Extra

SERA SERVICE

INDEPENDENT ELECTRONIC REBUILDER

2343 N.W. 20 Street
Miami, Florida 33142
(305) 642-4000

EXCELLENCE IS FOUND WITH SPECIALIZATION
WE SPECIALIZE IN ZENITH

Circle (41) on Reply Card

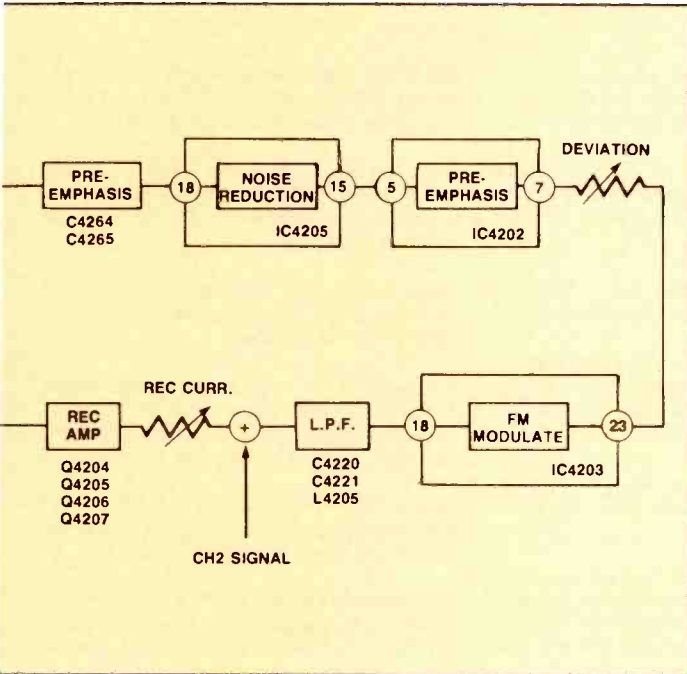

the amount of noise recorded on the tape. In playback, the dynamic range is expanded back to its original characteristics.

FM modulation

The FM modulator (IC4203) modulates the left channel at $1.3\text{MHz} \pm 150\text{kHz}$ and the right channel at $1.7\text{MHz} \pm 150\text{kHz}$. A voltage-controlled oscillator, responding by frequency shifts to incoming signal-level amplitudes, acts as the FM modulator. The output of the modulator contains high-frequency harmonics that are removed by the next stage, the low-pass filter.

The left- and right-channel audio signals are then added and applied to the audio heads through a record amplifier.

During the recording process, both the VHS high-fidelity and the normal linear audio tracks are recorded simul-

The output of the modulator contains high-frequency harmonics that are removed by the next stage, the low-pass filter.

taneously (except for dubbing modes, when only the linear tracks are recorded). During playback, the VHS high-fidelity, linear audio tracks or combinations of both can be selected.

Next month's Video Corner will describe the playback circuitry.

ES&T

Readers' Exchange

WANTED

Schematics and/or other repair information for the SEGA video game system. *Guy Stuller, 2144 S. 60th St., West Allis, WI 53219; 414-543-8891.*

"Radiotron Designer's Handbook" by F. Langsford Smith—not the short (352-page) version. *Alan Rauchwerger, 173 Howard Ave., Rochelle Park, NJ 07662-3509; 201-843-3213.*

Schematic for Sony radio MR-9700W; Sams manual #TSM-141; VCR repair tools—i.e., tape-tension gauge, etc. *Ed Herbert, 410 N. Third St., Minersville, PA 17954.*

Knight 83Y135 signal tracer with manual; Knight 83YX137 AF generator with manual; TEKFAH 100, 102, 117. *C.T. Huth, 229 Melmore St., Tiffin, OH 44883; 419-448-0007.*

Schematic for a "stage" 740-P PA amplifier. Will pay any reasonable amount or will copy and return. *M.A. Morales, 2265 Davidson Ave., Bronx, NY 10453-1620; 212-367-4852.*

Beta VCRs: Sanyo 7300, Sony SL-2710, Sony SL-5200. State condition and price. *Robert Shafer, Engineering Services Company, 8119 S. Sandy Hook Terr., Clinton, WA 98236; 206-321-5178.*

Service and repair manual for Grundig Color TV Series F3020, chassis CUC 220 (made in Austria, sold in U.S.); also distributor for parts. *A.E. Still, Jr., Still's TV Service, 305 Lamar St., Greenwood, SC 29646.*

Schematic/service manual for an Electrotec model To-55, 5-inch oscilloscope, manufactured by Electrotec, Chicago. Will pay reasonable price. *Gerald Maurice, Maurice TV Service, 165 Howard St., Northboro, MA 01532; 617-393-3106.*

Supremes TV-1, TV-2, TV-11 and R-1 manuals. *C.T. Huth, 229 Melmore St., Tiffin, OH 44883; 419-458-0007.*

Flyback #EP77X22 for GE TV, chassis #13YA, model #YA5508WD. Will consider purchase of complete chassis. *Jerome Graham, 4030 Barksdale Court, Dallas, TX 75211; 214-337-1204.*

Used oscilloscope, bandwidth should be broad enough to do TV service work. *Arthur Stohr, 1803 Ninth St., Columbus, NE 68601; 402-564-8287.*

Schematic or Xerox copy for Panasonic model TC-261 NP, chassis PBXM8X. Is unavailable from normal sources. Will pay \$10. *Augustine's TV & Radio Service, 530 N. Ninth St., Reading, PA 19604; 215-372-5438.*

B&K model 1050 telephone product analyzer or similar equipment. State condition, price. *Joseph Silver, 260 Candlewood Road, Rochester, NY 14609; 716-654-8370.*

S-meter for a Hallicrafters model SX-28 radio; Ceco diode tester. *Paul Capito, 637 W. 21st St., Erie, PA 16502.*

Hitachi dual-trace oscilloscope, model V-422 (40MHz) or V-660 (60MHz); Heathkit signal tracer. *George John Demaris, 7387 Pershing Ave.,*

Orlando, FL 32822-5743; 305-277-3746.

Apple computer diagnostic software and service literature. *Bill Bamert, KBS Systems, 105A Bassett Highway, Dover, NJ 07801; 201-366-9787.*

Service manual for Sinclair DM450 digital multimeter; operator's manual for Singer electronic calculator, model 1117. *Eino O. Williams, 18 Russell Ave., Troy, NH 03465.*

VCR service manuals for VCR repairs. *Ed Herbert, 410 N. Third St., Minersville, PA 17954.*

Gemtronics GT50 or Pearce-Simpson "Nassau" VHF Marine chassis or complete unit for parts. *Mark A. Moorman, P.O. Box 2923, Greenville, NC 27836; 919-756-0004, 919-757-6018.*

Sams Photofacts folders from #2000 up, please send list. *Sal Cribari, 1312 Well Drive, Camp Hill, PA 17011; 717-763-4547.*

RCA CTC 25XA color TV chassis in good condition with tuner, voke and convergence board but without picture tube. Please quote price. *A. Wilson, #1611, 7420 Westlake Terr., Bethesda, MD 20817.*

Service/operator's manual for McADAM Electronics model 2000A digital audio analyzer system; service/operator's manual for McADAM's model 1000 wow and flutter analyzer. Will pay copying and mailing costs. *Eric Rush, 49 John St., Cranford NJ 07016; 210-276-2045.*

Score DVM 37. *Alan Weinberg, 1742 Avenida Sirio, Tucson, AZ 85710; 602-750-0393.*

Sams Photofacts (#1500 and up) and other service literature and microfiche. Prefer response from CA, AR or NV. *Frank Eichler, 79651 Highway 111 #17, La Quinta, CA 92253; 619-347-3545 or 619-398-4214.*

Two Motorola IC-21 (Philco), GEIC-224 or ECG782 Chroma Demod IC; no longer available. *Lee Johnson, 12807 Climbing Ivy Drive, Germantown, MD 20874; 301-972-5226.*

Flyback and picture tube for Philco Predicta model 4242L. Send price. *J. Pile, 4726 49th Ave. S., Seattle, WA 98118.*

Sams #1299-2 and #1862-1 or copy of parts layout and schematic for TV sets: RCA model ED433W, ser. 93534-1659; Quasar-Motorola model WU904HW, ser. F2084-2378, chassis TS933-FD7. State prices. *Robert R. Blevins, Box 113A Route 1, Lexington Park, MD 20653; 301-863-8687.*

Information—Does anyone know if Toshiba T-100 cable converters can be converted to use as normal converters? *Lawrence Churchill, 513 N. Clark St., Mayville, WI 53050.*

Schematic and service information for a Scottkit FM tuner, model LT-112B. Manufacturer cannot supply. *Ed Bolt, P.O. Box 1035, Ft. Collins, CO 80522; 303-490-1945.*

Schematic and parts list for Sanyo model 91C50, chassis PL50000; Sams Photofact lists 91C50N but it's not the same. *C.E. Hess, 201 S. Oak St.,*

Buchanan, MI 49107; 616-695-6602.

200 MBK high-voltage resistor RC25HVT, Kamaya 12203A for Mga TV. *Boyd Hawks TV Service, Route 3, Box 496, Galax, VA 24333.*

B&K model 161 transistor analyst; Hickok LX303/4 DVM; Hickok model 230 tube tester. *Kenneth Miller, 10027 Calvin St. Pittsburgh, PA 15235; 412-242-4701.*

Norelco model L6X38T/54 radio, prefer it to be working but will discuss any condition. *Joe, Sr., 516-931-7528, call anytime.*

Seco model 78 tube tester, good condition; volume 1, "Basic Solid State" by John F. Rider, plus other electronics books. *Larry Cook, 362 E. South St., Richland Center, WI 53581; 608-647-4678.*

Owner's manual for General Radio UHF signal generator, type number 804-B. *Louis K. Yadevia, 601 Church Lane, Upper Darby, PA 19082.*

Record-cutting machine for 78s and 45s. Must be portable, any condition. *Mike Zuccaro, 8795 Coruus Place, San Diego, CA 92126; 619-560-1166 days, 271-8294 nights/weekends.*

Technical data or source of same on the following: AN 7810 in a To-220 case, a 10V voltage regulator (VR); AN7824 in a To-220 case, a 24V VR; LM309 in a To-5 case, a 5V IC VR. Derived this from parts and circuit. *O. Sellers, 7308 Franklin Drive, Bessemer, AL 35023-5557.*

Manual for Lectrotech model V7 vectorscope. Will pay for or copy and return. *Lurry, 619-462-7445.*

Schematic for GE color TV 19YC9762 KE01, Sams 1804; KRK-237A tuner for RCA color TV, chassis CTC 85A. *4366 Eastport Drive, Bridgeport, MI 48722; 777-2494.*

Microwave oven leakage tester; manual for Fairchild 766H type 76-08/type 74-20A. Will trade training video tapes. *Clarence Wilken, 40 N. Bailey, Freeport, IL 61032; 815-938-2564.*

Philco Predictas and parts, including flybacks 32-88xx and Fly 196; picture tubes 17DAP4, 17DRP4, 21EVP4. *Doug Heimstead, 1349 Hillcrest Drive, Fidelity, MN 55432; 612-571-1387.*

FOR SALE

Aiwa model PI71 portable AM-FM-SW-phonos, \$25; Orion model V-100 M VTVM, \$20; Military VTVM, model ME-6D/U, \$15; Hickok model 6000 tube tester, \$50. Add shipping cost. *Donald H. Nash, 1444 Pulaski St., Port Charlotte, FL 33952; 813-629-3934.*

IG5280 RF generator, unassembled, \$35; Score FE-20, recently factory calibrated, \$85; B&K 1805 80MHz, multifunction frequency counter, used only once, \$200. Or best offers, plus shipping. *Stanley Todorow, G8468 Belle Bluff Drive, Grand Blanc, MI 48439; 313-695-0271.*

Heath Kit IG-37 FM-stereo generator with test lead; Eico 460 oscilloscope, dc wideband; Conar 311 R-C tester; all include manuals and are in excellent condition. Complete price: \$130 plus

shipping; will accept equal value trade for a Heath Kit IM-2400 frequency counter or a Heath Kit antenna tuner, model SA-2040 in good working condition. Send s.a.s.e. or phone 216-530-9455. *J.J. Franco, 803 New Jersey Ave., McDonald, OH 44437.*

Low-priced tubes—new, used, rare or current. Low prices, fast service. Send list for quote. *Ted Youngman, 2225 Vigo, St., Lake Station, IN 46405.*

50 unused B&W picture tubes, \$50 for all (picked up) or \$10 plus shipping for each; truckload of used TV sets and TV parts—FREE if picked up. *Jim Farago, P.O. Box 65701, St. Paul, MN 55165; 612-722-0708.*

Hickok 610A universal TV-FM alignment signal generator, with manuals, \$75 plus shipping; Sams Photofact sets, #69 through #496—all 275 sets for \$100 plus shipping. *John Brouzakis, 247 Valley Circle, Charterot, PA, 15022; 412-483-3072.*

MUST LIQUIDATE: All equipment and stock. Contact for details. *Dennis A. Hainke, 15770 Windward Way Circle #2102, Fort Myers, FL 33908.*

Nuvistors, mostly unused but some used for test only, \$5 each (send SASE for list); unused tubes, Raytheon branded and boxed: 5AQ5, \$5 each or 80 for \$200; 12BY7 at \$6 each or 60 for \$200. All prices postage-paid. *Donald H. Nash, 1444 Pulaski St., Port Charlotte, FL 33952; 813-629-3934.*

Simpson Electric model 467 true rms digital multimeter with batteries and leads, \$100; Dumont model 1062 oscilloscope, 50MHz bandpass, dual vertical inputs, main and delay sweeps, \$495; Deihl Mark III scanner, new, \$250. Add \$10 for insured UPS, COD ok. *Fred Jones, 407 Morn- ingbird Court, Niceville, FL 32578.*

Old used tubes, magazines, parts, Sams Photofacts, diagrams for radio and TVs, speakers, car radios. *Florian Rogowski, 25103 Cunningham, Warren, MI 48091.*

Scencore VA48 analyzer with TR219 horizontal output drive-isolation transformer, \$800 or best offer; B&K 1479 30M scope, \$400 or best offer. With leads and manuals. Add shipping. *John Dews, Dew Electronics, P.O. Box 20726, Montgomery, AL 36116; 205-288-8479.*

Hitachi V10S0F 100MHz quad trace (two probes), \$1,100; B&K 520 automatic transistor checker, \$150; Tequipment D54 scope, dual trace. 30MHz (no probes) \$250. *Joseph Silver, 260 Candlewood Road, Rochester, NY 14609; 716-654-8370.*

1,200 new radio and TV tubes (send request list); Sams #99 to #290, #888 to #959, make offer. *Reynolds Electronic Service Company, 1942 Sandalwood Lane, Fort Collins, CO 80526; 303-484-2715.*

Sony AV8600 open-reel color videotape recorder plus 12 tapes, good condition, view frame by frame, \$99 plus shipping (UPS). *John Augustine, 530 N. 9th St., Reading, PA 19604; 215-372-5438.*

Scencore LC53 Z-meter capacitor, inductor

analyzer, with pouch, manual, field calibration schematic, \$600. *R. Grafton, 1876 Perth Road, Madison, OH 44037.*

Vacuum tubes: TV, some radio, more than 1,200 boxed. 150 not boxed, \$500. List available on request. Will ship UPS. *R.C. Van Wagner, 16 Lacy Lane, Clarksville, TN 37043; 615-645-7247.*

Scencore SC-61 waveform analyzer, VA-62 video analyzer, TF 46 Super Cricket, DVM 56A milliammeter, like new, \$5,500 or B.O. *Ty, Alabama*

Electronics, 1506 Gault Ave. N., Fort Payne, AL 35967; 205-845-6131.

B&K model 467 CRT analyzer and restorer, \$245; Telematic color jig, \$95; B&K model 2120 dual-trace, 20MHz scope, new, \$265. Add shipping. *George C. Pullen, 8601 Temple Hills Road, Lot 122, Temple Hills, MD 20748; 301-297-9374.*

B&K 1590A 100MHz, 4-channel scope with accessories, \$900; Leader LBO-518 100MHz.

Continued on page 67.

BK

INSTRUMENT SALE!

Joseph Electronics' 40th Anniversary Specials!



Model 2120 Oscilloscope

Model 2120 Oscilloscope DC to 20 MHz. Dual Trace, 6" CRT-1mv Sensitivity
Reg. \$479 **\$379.40**
40TH ANNIVERSARY PRICE

Model 2125 Oscilloscope Same great features as 2120, except with delayed sweep
Reg. \$577 **\$469.40**
40TH ANNIVERSARY PRICE

Model 1541A Oscilloscope DC to 40 MHz. Dual Trace, 6" CRT 1mv Sensitivity
Reg. \$845 **\$739.40**
40TH ANNIVERSARY PRICE

Model 2520 Digital Storage 20MHz, Dual Trace, 2mv Sens.
Reg. \$1990 **\$1795.40**
40TH ANNIVERSARY PRICE

Model 2521 Digital Storage 20MHz, Dual Trace CRT Read-out, Cursors, RS232 Interface
Reg. \$3C50 **\$2745.40**
40TH ANNIVERSARY PRICE



Model 3011 Function Generator

Model 1249 NTSC/RGB Color Bar Generator, Composite Video Output, RF Output
Reg. \$475 **\$399.40**
40TH ANNIVERSARY PRICE

Model 2009 MTS TV Stereo Generator ideal for Stereo TV, Receivers, VCR's and Stereo Adapter Service
Reg. \$495 **\$419.40**
40TH ANNIVERSARY PRICE

Model 2830 3-1/2 DIGIT LED BENCH Multimeter .5 DCV Accuracy, ALL 33 Ranges and Functions are Push Button Selectable
Reg. \$233 **\$199.40**
40TH ANNIVERSARY PRICE

Model 1045 Telephone Product Tester Provides Basic Operation Tests for Corded and Cordless Telephones, Answering Machines and Automatic Dialers
Reg. \$471 **\$399.40**
40TH ANNIVERSARY PRICE



Model 1630 Power Supply

Model 1603 Frequency Counter 100 MHz 8 digit display, zero blanking AC or Battery
Reg. \$186 **\$159.40**
40TH ANNIVERSARY PRICE

Model 2005 RF Signal Generator 100 KHz to 150 MHz, in 6 fundamental bands and 450 MHz in harmonics
Reg. \$195 **\$169.40**
40TH ANNIVERSARY PRICE

Model 1630 DC Power Supply 0-30V, 0-3A, high-low current range, Low ripple
Reg. \$233 **\$199.40**
40TH ANNIVERSARY PRICE

Model 1601 DC Power Supply isolated 0-50V, 0-2A in ranges, fully automatic shutdown, Adj. current limit
Reg. \$440 **\$369.40**
40TH ANNIVERSARY PRICE

Model 1650 Triple Output Power Supply two 0-25 VDC @ .5A and 5VDC @ 5A, fully automatic shutdown
Reg. \$455 **\$379.40**
40TH ANNIVERSARY PRICE

Model 1653 AC Power Supply variable isolated 0-150 VAC @ 2A, built-in isolation transformer
Reg. \$190 **\$169.40**
40TH ANNIVERSARY PRICE

We are celebrating our 40th Anniversary by offering you huge savings on B&K Test Equipment.

Send for FREE 480 page "Industrial Products Catalog". I understand it is FREE with any order or if requested on company letterhead. (Otherwise, \$4.95 to cover catalog and shipping costs.)

**ORDER TOLL FREE
1-800-323-5925
IN ILLINOIS
312-297-4200
FAX: 312-297-6923**

Our 40th Year



IL Res. 7% Tax City State Zip

JOSEPH ELECTRONICS, INC. Dept. F
8830 N. Milwaukee Ave., Niles, IL 60648

Rush merchandise per attached order.
I understand rated accounts are shipped open account; otherwise send per credit card.

Include \$5.00 per item for shipping and handling.

Visa Master Card Discover
 Check Money Order Rush Catalog

Card No. _____ Exp. Date _____

Name _____
Company _____
Street Address _____
City _____ State _____ Zip _____

Circle (42) on Reply Card

Learn how to...

- *Expand your market and increase sales...*
- *Overcome price objections...*
- *Price your services competitively...*
- *Increase your market visibility*

The answers are now available in the new, comprehensive research report: Opportunities In Personal Computer Servicing: A National Survey of Malfunction and Repair.

Achieve greater profits for your service company today, and for years to come. Only \$299 for the complete report.

Order now; supplies are limited!

EXCLUSIVE!

Research jointly conducted by Business Products Consulting Group and *Microservice Management* magazine.

SEND ORDER TO:

Microservice Management and
Business Products Consulting Group
24 Fort Salonga Road
Centerport, NY 11721
Attn: Justin Thompson
(516)261-8000

Allow 6-8 weeks for delivery.

My check is enclosed. Rush my copy of "Opportunities in Personal Computer Servicing: A National Survey of Malfunction and Repair." I will expect my research report within four to six weeks.

NAME _____

COMPANY _____

ADDRESS _____

CITY _____ STATE _____ ZIP _____

4-channel scope, \$900; Tektronix 465 100MHz scope, \$1,000. Other equipment available. *Roger Briggs, 983D Ponderosa Ave., Sunnyvale, CA 94086; 408-730-4573.*

138 Sams Photofacts, including #1984-2005, #2110-2172 and others, \$225 for all. *Bill Leer, R840 Emerald Lane, Edgar, WI 54426; 715-257-7214 evenings.*

B&K model 600 tube checker, \$40; Hickok model 385 scope, 3-inch CRT, \$45; Heath wireless intercom, 2-stations, \$25; Lafayette stereo amp (20W), \$25. *Leonard Duschenchuk, Chuck's TV, 255 Stewart Ave., Bethpage, NY 11714; 516-731-3868.*

B&K NTSC model 1251 generator, \$750; B&K model 415 sweep/marker generator with cables, \$250; RCA model 33B 3-inch scope, built-in curve trace, \$75. Prepaid UPS. *ALCO Video Service, 4132 W. Lincoln Ave., Cypress, CA 90630; 714-527-9060 or 213-439-8707.*

Dozens of antique radio and TV receiving tubes, most in original boxes. Send for list. *Frank Salerno, 349 W. Cortland Ave., Oceanside, NY 11572; 516-678-3826.*

Text books; service manuals; radio and TV tubes 90% off list price; radio and TV parts. Send large SASE for list. *M. Seligsohn, 1455 55th St.,*

Brooklyn, NY 11219.

ES&T magazines, 193 issues, \$200; NRI color TV servicing course and NRI videocassette recorder course, \$150; Sencore SC61 60MHz dual-trace waveform analyzer with probes and adapters, \$2,500; Sencore VA62 universal video analyzer with accessories, \$3,000. With manuals. Send large SASE for list of other equipment. *Clarence G. McKee, 9516 Zion Road, Rives Junction, MI 49277; 517-569-3139.*

Sencore VA62, NT64, VC63, SC61 scope, Cricket checker, PR-57 and Z-meter with boxes, manuals and leads, about 30 hours of use, \$6,000 firm. *Chuck Vostry, HCR2 Box 65A, Dumas, TX 79029; 806-935-4040.*

B&K 1076 analyst, \$75; B&K 466 pix tube rejuvenator with adapters, \$100; Sencore TC 162 Mighty Mite VII tube tester with latest chart, \$50. *Stanley Chalker, Kodak Retina SVC, 1176 Smithsonian Ave., Youngstown, OH 44505.*

Sencore model SM158 sweep/marker generator, \$50; Heathkit IT-5230 CRT tester/rejuvenator, \$50. Both include manuals. Also parts for GE 13ACK509W and Sony KV1722, modules for Zenith 19FC45. *Seng, 612-489-4850 after 3 p.m.*

Sencore VA-62 video analyzer with VC-63 accessory, all probes, manuals and test leads, in-

cluding TP212 HV probe, perfect condition, \$2,900. Will trade for Sencore SC-61 scope. *Michael E. Carter, NCS Box #7, FPO NY 09539.*

HP model HP41CX hand-held computer, with manuals, \$100; Heathkit model IP-17 power supply, with manuals, \$50. *Dennis Dillon, 1616 S. 94th St., West Allis, WI 53214; 414-774-2255.*

Heathkit model IO-101 vectorscope with manual and leads, \$30 plus shipping. Used little, looks like new. *J.R. Gulick, 2615 Hemlock Court, Titusville, FL 32780; 305-269-9752.*

Thordarson-variety of horizontal transformers, mostly color, some B&W, high-voltage, \$15 each, plus shipping; TV and stereo parts; variety of odd-ball tubes. SASE for details. *Boyd Hawks TV service, Route 3 Box 496, Galax, VA 24333; 903-236-4210.*

B&K model 1050 telephone analyzer with cables and manual, used less than one year, will sell for \$1,200; Leader model LSG532 sweep marker generator with some cables and manual, \$50. *J.S. Lawrence, Jr., Mountain City TV, 2646 S. Broad St., Chattanooga, TN 37408; 615-756-5430.*

Parting-out Sony 19-inch color TV with remote, model no. 1943 R. *James E. Gregorich, 117 2nd St. N., Virginia, MN 55792; 218-749-4355.*

ES&T

Classified

Advertising rates in the Classified Section are \$1.55 per word, each insertion, and must be accompanied by payment to insure publication.

Each initial or abbreviation counts as a full word.

Minimum classified charge \$30.00.

For ads on which replies are sent to us for forwarding (blind ads), there is an additional charge of \$35.00 per insertion to cover department number, processing of replies, and mailing costs.

Classified columns are not open to advertising of any products regularly produced by manufacturers unless used and no longer owned by the manufacturer of distributor.

FOR SALE

VCR REPAIR SOLUTIONS FOR VHS MODELS. Volume 1-150 Symptoms and cures-\$11.95. Volume 2-\$11.95. All 300, \$19.95. Eagle Electronics, 52053 Locks Lane, Granger, IN 46630. 12-87-6t

TV TOUGH DOGS: 300 symptoms and cures. Send \$7.95 to DAVIS TV, 11772 Old Fashion Way, Garden Grove, CA 92640. 10-87-1fn

SONY-TRINITRON Rebuilt Picture Tubes are now available. All tubes shipped U.P.S. No Charge. We buy all Sony duds. Rochester Kinescope, 716-235-0750. 11-87-1fn

PHOTOFACTS: Individual folders #1400 \$3.00. Above #1400 \$5.00. Sent same day first-class postpaid. Loeb, 414 Chestnut Lane, East Meadow, NY 11554. 12-87-6t

SENCORE VA-62 VIDEO ANALYZERS and accessories. Mint condition, excellent price. Call (314) 773-0470 Days, (314) 653-1977 Nights. 4-88-1t

AUTOMOBILE RADIO and tape replacement parts. Delco, Ford, Chrysler, Mitsubishi, Fujitsu, Panasonic and many others. Large inventory. Laran Electronics, Inc., Mount Vernon, NY. Inquiries, P.O. Box 466 Bronx, NY 10475, 914-664-8025 or 800-223-8314. 2-88-1fn

TV/VCR "Tuff Tips" listed by mfg. and model. 1st or second edition, 200 tips per edition. \$10.95. both editions \$19.95. TV tips only. 1st or 2nd edition. \$5.95. both editions \$10.95. VCR tips only. 1st or 2nd edition. \$6.95. both editions \$12.95. **TECH CURES.** 4825 Fredricksburg Road, San Antonio, Texas. 03-88-2t

TV/VCR Failure Histories—Multiple cures for most problem areas. Send \$6.95 with mfg. and model number to **TECH CURES.** 4825 Fredericksburg Road, San Antonio, TX 78229. Money will be refunded with free sample, if model is not on database. 03-88-2t

VCR CROSS-REFERENCE listing for the following electronically-similar manufacturers: RCA, GE, Sylvania, Panasonic, Quasar, Magnavox, Philco and J.C. Penney. Send \$13.95 to **TECH CURES.** 4825 Fredericksburg Road, San Antonio, TX 78229. 03-88-2t

INTEGRATED CIRCUITS—Lowest prices on Admiral, GE, NAP, Philco, RCA, Sears, Sylvania, and Zenith types. Write P.E.C. Box 894 Union, NJ 07083. 03-88-6t

TV TROUBLESHOOTING: 156 Problems—Solutions on models/chassis in service today. Nothing old listed. Complete narrative on each solution. Also, 15 effective steps to easier repairs, \$12.00. Jones, Box 702, Niceville, FL 32578. 2-88-6t

CLOSING OUR TV, COMPUTER, & STEREO service center. \$50,000.® of instruments, parts, and manuals at package price of \$5,000. Retiring owner will deliver. 1-303-641-4678. 4-88-1t

"UNCLE JON'S SEMICONDUCTOR CRISS-CROSS" 1000's of TV, VCR, and audio ICs and transistors cross referenced **FROM** General Purpose Replacement Part Numbers (ECG*, NTE**, and others) TO RCA, Zenith, GE and many Japanese part numbers. If you need a type 712 TV sound IF/Detector, don't order an expensive replacement, check your stock for EP84x73(GE), HA1124(Hitachi), or AN240(Matsushita). Pays for itself the first time you use it. \$8.95 Ea. Uncle Jon's Video Service Co., 12871 Briarwest Circle, Houston, Texas 77077. (*®Philips ECG, **®NTE). 4-88-3t

UNIVERSAL CRT REFERENCE BOOK now available from Dandy Mfg. Co., 2323 Gibson, Muskogee, OK 74403. A valuable sservice aid which details basing/pinout sequence for heaters, cathodes, G1's & G2's for all Color CRT's, Projection, Camera and Oscilloscope, (Asian, European & domestic from 1949 to 1988). Chargecards/cash/checks/MO's. No COD's. \$10.00 Toll free 1-800-331-9658. 2-88-1t

BUSINESS OPPORTUNITIES

TV/VCR SALES & SERVICE; well established, fully equipped. Located in northern Virginia, highest growth area in U.S. Retiring because of health reasons. Call 703-972-7027 after 7:00 PM EST. 12-87-1fn

T.V. REPAIR STORE, service, used T.V.'s, great location. Building 3 year lease. Located Sweet Home, Oregon. Call Holley Real Estate, (503) 367-6364. 4-88-1t

TV/ELECTRONIC REPAIR. Authorized by RCA, GE, Sony, Sears, Penney's, others available. All inventory, test and office equipment. \$36,000 with 1987 Van, \$27,000 without. S.W. Wyoming—Great hunting and fishing! (307) 877-9533 OR (307) 877-6490. 4-88-1t

WANTED TO BUY

WANTED: CRT rebuilding equipment, working or not. Contact: Chicago TV, 633 North Semoran Blvd., Orlando, FL 32807. Call 305-275-9543. 03-88-2t

POSITION WANTED

SITUATION WANTED Tech heavily experienced in VCR, Camcorders, TV's, Computers etc. seeks high pay, good benefits, etc., with firm desiring to venture into the future of servicing, and remain! Have extremely fast troubleshooting skills to component level, and management experience. Factory trained, tech schooled, 20 years on the bench, and ready to relocate. Write to Video Tech, 103 Montleau Ave., Salisbury, MD 21801. 03-88-1FN

ATTENTION TECHNICIANS

- ★ JOB OPENINGS
- ★ MONTHLY TECHNICAL TRAINING PROGRAM
- ★ BUSINESS MANAGEMENT TRAINING
- ★ LOW COST INSURANCE
- ★ CERTIFICATION
- ★ TECHNICAL SEMINARS

All of this in a nonprofit international association for technicians

FIND OUT MORE:



604 N. Jackson St.
Greencastle, IN 46135



"Tech's Guide To Pricing"
updated new 5th edition... a framework for setting rates that apply to Hi-Tech products... a formula that guarantees SUCCESS!
Call Toll Free for details
1-800-228-4338 8/5 CST

Circle (45) on Reply Card

**PERSONALIZED 24-HOUR SERVICE
ON OVER 10,000 ELECTRONIC
COMPONENTS & PRODUCTS...**

CALL TOLL FREE

IN
1-800-558-9572 WIS **1-800-242-9553**
24 HOUR ORDERING: FAX: 414/473-4727



PROJECTOR-RECORDER BELT CORP.
P.O. Box 176 • Whitewater, WI 53190
TLX 4994411 PRBUSA

Circle (44) on Reply Card

TV "TECH'S" DREAM

TEST & RESTORE EVERY CRT on the market.... without every buying another adaptor socket for your CRT tester. Fits ALL makes & models. **MONEY BACK GUARANTEE.** Over 12,000 sold. Complete Patented Kit, with Sockets & Setup Book.... Only \$63.95 ppd. A one-time investment for life!! Visa/MC/COD's/Checks.
FREE CALL 1-800-331-9658
DANDY MFG. CO.

2323 Gibson Street Muskogee, OK 74403

Circle (43) on Reply Card

Ad Index/Hotline

Company	Page Number	Reader Service Number	Advertiser Hotline
American Reliance	51	34	800/654-9838
Automated Production Equipment Corp.	27-28	21	516/654-1197
B&K Precision Dynascan Corp.	7,50-55	6	312/889-9087
Beckman Industrial Corp.	IFC	1	619/495-3200
C + S Sales	48	31	800/292-7711
Chemtronics, Inc.	1	3	800/645-5244
D.A.T.A., Inc.	43-44	27	800/854-7030
Dandy Mfg. Co.	68	43	800/331-9658
E-Z-Hook	27-28	22	818/446-6175
Eta	68		
Fluke, John Mfg. Co., Inc.	5,9,21	5,7,14	800/227-3800
Fluke, John Mfg. Co., Inc.	8A-B		800/227-3800
Iscet	51		817/921-9101
JDR Instruments	IBC	2	800/538-5000
Joseph Electronics	65	42	800/323-5925
Kikusui International Corp.	47	30	800/545-8784
Leader Instrument Corp.	3,27-28	4,46,20	800/645-5104
MCM Electronics	62	40	800/543-4330
NESDA	14		
NRI Schools-Electronics Division	25-26		202/244-1600
NTE Electronics, Inc.	41-42	25	800/631-1250
OK Industries, Inc.	49	32,63,64,65,66	800/523-0667
Parts Express Int'l. Inc.	12	8	513/222-0173
Projector Recorder Belt Corp.	68	44	800/558-9572
RCA Distributor and Special Products	19,25-26	13,19	
RNJ Electronics, Inc.	24	15	800/645-5833
Sencore, Inc.	53,55,57,59	35,36,37,38	800/843-3338
Sera Service	63	41	305/642-4000
Specialized Products Co.	25 & 26	47	800/527-5018
Sperry Tech, Inc.	68	45	800/228-4338
Tab Books	41-42	24	800/233-1128
Techni-Tool	43-44	28	215/825-4990
Tektronix, Inc.	13,15,17,45,61	9,11,12,29,39	800/433-2323
Tektronix, Inc.	16A-B		800/433-2323
Tronix, Inc.	14	10	313/939-4710
Tucker Electronics	41-42	23	800/527-4642
U.S. Instrument Rentals	43-44,50	26,33	800/824-2873
U-Can-Do VCR Educational Products Co.	24	16	513/548-6113
Walker, D.S. & Associates	62	48	713/890-2257
Zenith	BAC, 24A-B		

**Use ES&T
classified
ads**

ELECTRONIC SERVICING & TECHNOLOGY Volume 8, No. 4 (USPS 462-050) is published monthly by Intertec Publishing Corp., 9221 Quivira Road, P.O. Box 12901, Overland Park, KS 66212. Second Class Postage paid at Shawnee Mission, KS, and additional mailing offices. POSTMASTER: Send address changes to ELECTRONIC SERVICING & TECHNOLOGY, P.O. Box 12952, Overland Park, KS 66212-9981

ADVERTISING SALES OFFICES

ELECTRONIC

Servicing & Technology

ALL U.S. TERRITORIES
Greg Garrison, Sales Manager
P.O. Box 12901
Overland Park, KS 66212
Phone: (913) 888-4664
Fax: (913) 888-7243
Telex: 42-4156 INTERTEC OLPK

NORWOOD, AUSTRALIA
Hastwell, Williamson, Rouse PTY. LTD.
P.O. Box 419
Norwood, S.A. 5067
Phone: 332-3322
Telex AA 87113

OXFORD, ENGLAND

Nicholas McGeachin
Roseleigh House, New Street
Deddington, Oxford OX5 4SP
Phone: (0869) 38794
Telefax: (0869) 38040
Telex: 837469 BES G

TOKYO, JAPAN

Haruki Hirayama,
EMS, Inc.
Sagami Bldg., 4-2-21, Shinjuku,
Shinjuku-ku, Tokyo 160, Japan
(03) 350-5666
Telex: 2322520 EMSINCRJ
Cable: EMSINCPERIOD

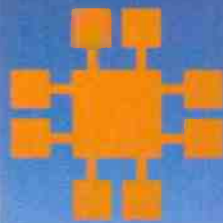

JDR INSTRUMENTS™

Complete customer satisfaction... superior service... friendly, knowledgeable personnel... quality merchandise... providing the best values in leading edge technology.

FULLY OVERLOAD PROTECTED

TRANSISTOR TESTER

9 FUNCTIONS 34 RANGES

CONDUCTANCE TESTER ADDS VERSATILITY

TEMPERATURE TESTER TO 2000° F



Our DMM-300 A remarkable value!

79.95

This full function 3.5 digit DMM offers highly accurate performance and a host of added features to help you do the job—fast. Capacitance, transistor, temperature, conductance and audible continuity in addition to the ranges you'd expect from a DMM of this quality. Temperature probe, test leads and battery included. Input impedance 10M ohm. Basic DC accuracy: plus/minus 0.25%. Approx. 7" x 3 1/2" x 1 3/4" Wt. 13 1/2 ozs.

DC VOLTAGE TO 1000 VOLTS

AC/DC CURRENT 200µA to 10A

CAPACITANCE TESTER 2000pF to 20µF

DPM-1000 \$54.95

3.5 DIGIT PROBE TYPE DMM

Custom 80 pin LSI chip provides accuracy and reliability in such a compact size. Autoranging, audible continuity and data hold feature help you pinpoint the problem quickly. Case and batteries included.

- * Basic DC accuracy: plus/minus 1%
- * DC voltage: 2v-500v, autoranging
- * AC voltage: 2v-500v, autoranging
- * Resistance: 2k ohms-2M ohms, autoranging
- * Fully over-load protected
- * Input impedance: 11M ohm
- * Approx. 6 1/2" x 1" x 3/4" Under 3ozs.



- ★ **2 YEAR REPLACEMENT WARRANTY**
- ★ **30 DAY MONEY BACK GUARANTEE**
- ★ **TOLL FREE TECHNICAL SUPPORT**
- ★ **NEXT DAY AIR SHIP AVAILABLE**

MODEL 2000 \$389.95

20 MHz DUAL TRACE OSCILLOSCOPE

Model 2000 makes frequency calculation and phase measurement quick and easy. The component tester aids in fast troubleshooting. Service technicians appreciate the TV Sync circuits for viewing TV-V and TV-H and accurate synchronization of the video signal, Blanking, VITS, and V/H sync pulses.

- * Exceptionally bright 5" CRT
- * Built-in component tester
- * TV Sync filter
- * X-Y operation * 110/220 volts



MODEL 3500 \$499.95

35 MHz DUAL TRACE OSCILLOSCOPE

Wide bandwidth and exceptional 1mV/DIV sensitivity make the Model 3500 a powerful diagnostic tool for engineers or technicians at a remarkable price. Delayed triggering allows any portion of a waveform to be isolated and expanded for closer inspection. Variable Holdoff allows stable viewing of complex waveforms.

- * Exceptionally bright 5" CRT
- * Delayed and single sweep modes
- * Z axis intensity modulation
- * X-Y operation * TV sync filter
- * Fast 10ns rise time



DMM-200 \$49.95

3.5 DIGIT FULL FUNCTION DMM

Get highly accurate performance at a very affordable price. Rugged construction, 20 amp current capability and 22 ranges make it a perfect choice for serious field or bench work. Low battery indicator and tilt-stand. Probes and 2000 hour battery included.

- * Basic DC accuracy: plus or minus 0.25%
- * DC voltage: 200mv-1000V, 5 ranges
- * AC voltage: 200mv-750V, 5 ranges
- * Resistance: 200 ohms-20M ohms, 6 ranges
- * AC/DC current: 200µA-20A, 6 ranges
- * Input impedance: 10M ohm
- * Fully overload protected
- * Approx. 7" x 3 1/2" x 1 1/2" Wt. 11 ozs.



DMM-100 \$29.95

3.5 DIGIT POCKET SIZE DMM

Perfect for the field service technician. Shirt pocket size without compromising features or accuracy. Large, easy to read 1/2" LCD display. Fully overload protected or safety. 2000 hour battery life with standard 9v cell. Probes and battery included.

- * Basic DC accuracy: plus/minus 0.5%
- * DC voltage: 2v-1000v, 4 ranges
- * AC voltage: 200v-750v, 2 ranges
- * Resistance: 2k ohms-2M ohms, 4 ranges
- * DC current: 2mA-2A, 4 ranges
- * Input impedance: 10M ohm
- * Fully overload protected
- * Approx. 5" x 3" x 1". Under 7 ozs.

JDR INSTRUMENTS, 110 KNOWLES DRIVE, LOS GATOS, CA 95030
RETAIL STORE: 1256 SOUTH BASCOM AVE, SAN JOSE, CA (408) 947-8881

ORDER TOLL FREE 800-538-5000

COPYRIGHT 1987 JDR MICRODEVICES



Circle (2) on Reply Card

**For your own reputation
and in your customers' best interest
always insist on**

Genuine Zenith
Remanufactured Replacement Parts
Reconditioned and Serviced for Reliability
by Zenith People
as Knowledgeable and Dedicated as
Those Who Made the Originals!

One of the easiest, fastest, and surest ways for you to preserve the pedigree and maintain the quality of the Zenith products you service is with genuine Zenith replacement parts.

And at no time is this more critical than when you replace the more sophisticated components like modules, tuners, channel selectors and sub-assemblies.

Your participating Zenith parts distributor will supply you with a replacement remanufactured, reconditioned and serviced for reliability by Zenith people as dedicated and knowledgeable as those who made the original.

Equally important, the replacement module or sub-assembly you receive in exchange from your Zenith parts distributor

will most likely incorporate any Zenith factory-made modifications in effect at the time of remanufacture.

And nowhere else but in a participating Zenith parts distributor's Exchange Program can you get assurance that a replacement incorporates Zenith factory up-dates!

To learn the location of the Zenith R&R Exchange Counter in your area, simply complete and send in the postage-free Reply Card inside this issue of *Electronic Servicing & Technology*.

Look inside, complete the Zenith Reply Card and chances are we'll prove Zenith factory-fresh replacement modules and sub-assemblies are closer and more readily available than you realize!



The quality goes in before the name goes on.®

Zenith Service, Parts & Accessories • 11000 Seymour Avenue, Franklin Park, Illinois 60131 • A Division of Zenith Electronics Corporation